

50W isolated DC-DC converter  
Wide input and regulated single output

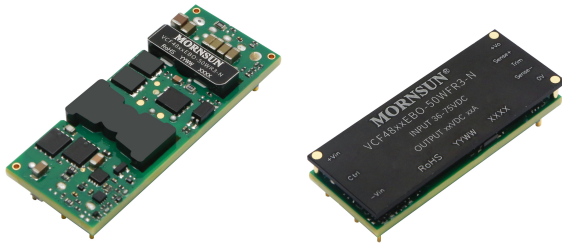

Patent Protection RoHS



## FEATURES

- Wide input voltage range: 36-75 VDC
- High efficiency up to 93%
- I/O isolation test voltage 2250 VDC
- Operating ambient temperature range: -40°C to +100°C
- Input under-voltage protection, output short circuit, over-current, over-voltage protection, over-temperature protection
- Industry standard package: 1/8 brick

VCF48\_EBO-50W(F)R3-N series is a high-performance product specifically designed for a variety of communication power supply field. The DC-DC converters feature 50W output power with an wide 2:1 input voltage and feature efficiencies of up to 93%, input to output isolation is tested with 2250VDC and the converters safely operate ambient temperature of -40°C to +100°C, input under-voltage protection, output over-voltage, over-current, short-circuit protection, over-temperature protection. Meets EN62368 standards. They are ideally and widely used in applications such as industrial control, electric power, instruments and communications.

## Selection Guide

Certification	Part No. <sup>①</sup>	Ctrl Logic <sup>②</sup>	Input Voltage (VDC)		Output		Full Load Efficiency <sup>④</sup> (%) Min./Typ.	Max. Capacitive Load(μF)
			Nominal (Range)	Max. <sup>③</sup>	Voltage (VDC)	Current (A) Max./Min.		
--	VCF4805EBO-50W(F)R3-N	N	48 (36-75)	75	05	10.0/0	90/92	4000
	VCF4812EBO-50W(F)R3-N				12	4.17/0	91/93	1680
	VCF4824EBO-50W(F)R3-N				24	2.083/0	90/92	1000

Notes:

- ① Use "F" suffix for heat sink mounting. We recommend to choose modules with a heat sink for enhanced heat dissipation and applications with extreme temperature requirements;
- ② "N" means negative logic;
- ③ Exceeding the maximum input voltage may cause permanent damage;
- ④ Efficiency is measured at nominal input voltage and rated output load.

## Input Specifications

Item	Operating Conditions	Min.	Typ.	Max.	Unit
Input Current (full load / no-load)	Nominal input voltage	--	1145/20	1200/30	mA
Reflected Ripple Current		--	30	--	
Surge Voltage	Continuous	0	--	80	VDC
	Transient (100ms max.)	-0.7	--	100	
Start-up Voltage		--	--	36	
Input Under-voltage Protection		26	29	--	
Start-up Time	Nominal input voltage & constant resistance load	--	--	100	ms
Input Filter		Pi filter			
Hot Plug		Unavailable			
Input Reverse Polarity Protection		Unavailable			
Ctrl <sup>①</sup>	Module turn-on	Ctrl pin pulled low to GND (0-1.2VDC)			
	Module turn-off	Ctrl pin open or pulled high (TTL 3.5-12VDC)			
	Input current when switched off	--	3	10	mA
Ctrl Start-up Delay Time		--	30	50	ms

Note: ① The Ctrl pin voltage is referenced to input -Vin.

### Output Specifications

Item	Operating Conditions		Min.	Typ.	Max.	Unit
Voltage Accuracy	0%-100% load		--	±1	±3	%
Linear Regulation	Input voltage variation from low to high at full load		--	±0.2	±0.5	
Load Regulation	5%-100% load		--	±0.5	±0.75	
Transient Recovery Time	25% load step change, nominal input voltage, di/dt=2.5A/us		--	200	500	µs
Transient Response Deviation	25% load step change, di/dt=2.5A/us	05V	--	±6	±10	%
		other	--	±3	±5	
Temperature Coefficient	Full load		--	--	±0.03	%/°C
Ripple & Noise <sup>①</sup>	20MHz bandwidth, nominal input voltage, 5%-100% load	05V, 12V	--	120	150	mVp-p
		24V	--	125	--	
Trim			90	--	110	%
Sense			--	--	105	
Over-temperature Protection <sup>②</sup>	Product surface max. temperature		--	135	--	°C
Over-voltage Protection	Input voltage range		110	125	160	%Vo
Over-current Protection			110	140	170	%Io
Short-circuit Protection			Continuous, self-recovery, time ≤ 3 seconds			

Note:  
 ①The "parallel cable" method is used for Ripple and Noise test, please refer to DC-DC Converter Application Notes for specific information. Ripple & Noise at <5% load is 5%Vo max.  
 ②The temperature of over-temperature protection of products with heat sink is subject to the internal device temperature.

### General Specifications

Item	Operating Conditions	Min.	Typ.	Max.	Unit
Isolation	Input-output Electric Strength Test for 1 minute with a leakage current of 1mA max.	2250	--	--	VDC
Insulation Resistance	Input-output resistance at 500VDC	1000	--	--	MΩ
Isolation Capacitance	Input-output capacitance at 100kHz/0.1V	--	1000	--	pF
Insulation type	Input-output	Basic insulation			
Operating Temperature	See Fig. 1	-40	--	+100	°C
Storage Temperature		-55	--	+125	
Storage Humidity	Non-condensing	5	--	95	%RH
Pin Soldering Resistance Temperature	Wave soldering, 10 seconds	--	--	+260	°C
	Soldering spot is 1.5mm away from case for 10 seconds	--	--	+300	
Shock and Vibration Test		10-55Hz, 10G, 30Min. along X, Y and Z			
Switching Frequency <sup>①</sup>	PWM mode	--	300	--	kHz
Altitude		Altitude: ≤4000m, Atmospheric pressure: 60~110KPa			
MTBF	Telcordia SR-332@25°C	2000	--	--	k hours

Note: ①Switching frequency is measured at full load. The module reduces the switching frequency for light load (below 50%) efficiency improvement.

### Mechanical Specifications

Dimensions	VCF48_EBO-50WR3-N	58.42 x 22.86 x 9.69 mm
	VCF48_EBO-50WFR3-N	58.42 x 22.86 x 12.7 mm
Weight	VCF48_EBO-50WR3-N	27.0g (Typ.)
	VCF48_EBO-50WFR3-N	35.9g (Typ.)
Cooling Method	Natural convection or forced air convection	

Electromagnetic Compatibility (EMC)

Emissions	CE	CISPR32/EN55032 CLASS A (see Fig. 6-1 for recommended circuit) /CLASS B (see Fig. 6-2 for recommended circuit)		
	RE	CISPR32/EN55032 CLASS A (see Fig. 6-1 for recommended circuit) /CLASS B (see Fig. 6-2 for recommended circuit)		
Immunity	ESD	IEC/EN61000-4-2	Contact $\pm 6$ KV	perf. Criteria B
	RS	IEC/EN61000-4-3	10V/m (see Fig. 6-1 and Fig. 6-2 for recommended circuit)	perf. Criteria A
	EFT	IEC/EN61000-4-4	$\pm 2$ KV (see Fig. 6-1 and Fig. 6-2 for recommended circuit)	perf. Criteria B
	Surge	IEC/EN61000-4-5	line to line $\pm 2$ KV (see Fig. 6-1 and Fig. 6-2 for recommended circuit)	perf. Criteria B
	CS	IEC/EN61000-4-6	3 Vr.m.s (see Fig. 6-1 and Fig. 6-2 for recommended circuit)	perf. Criteria A

Typical Characteristic Curve

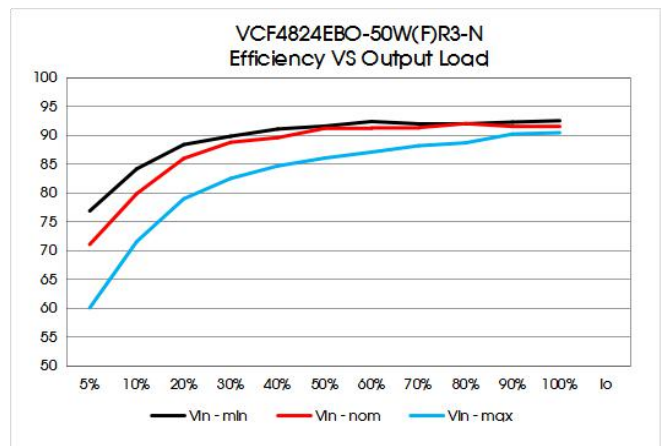
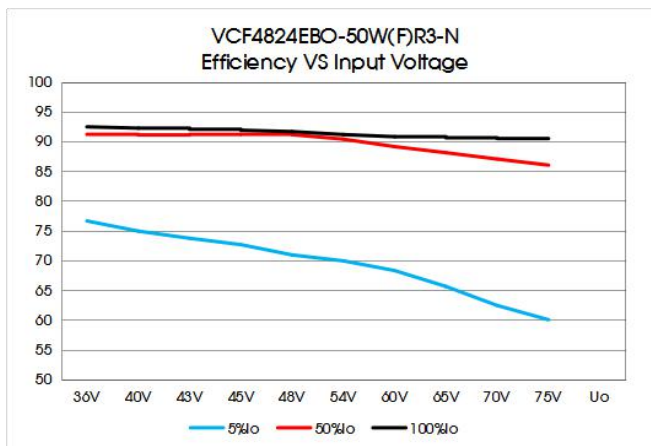
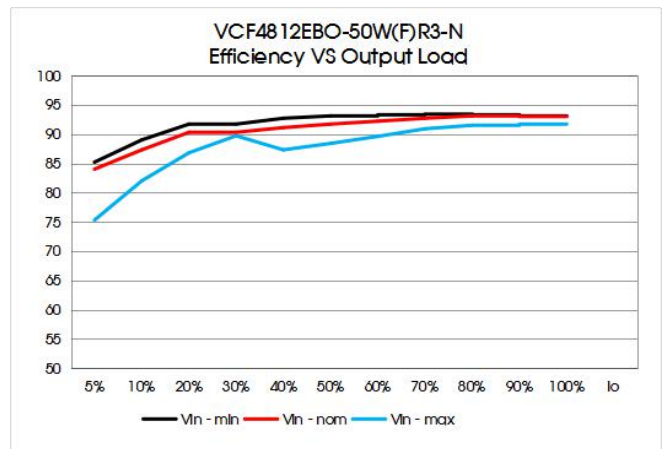
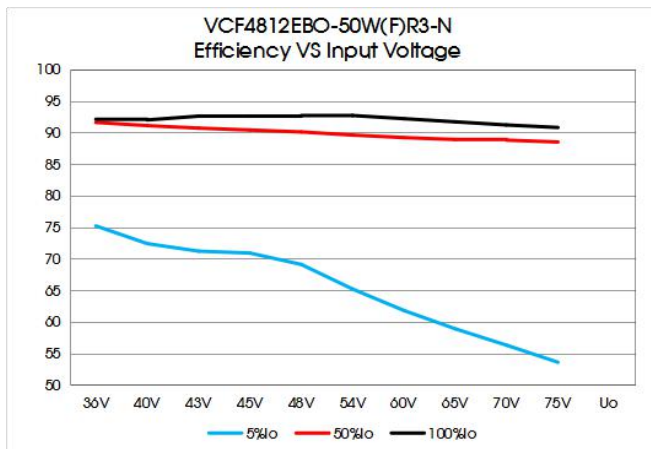
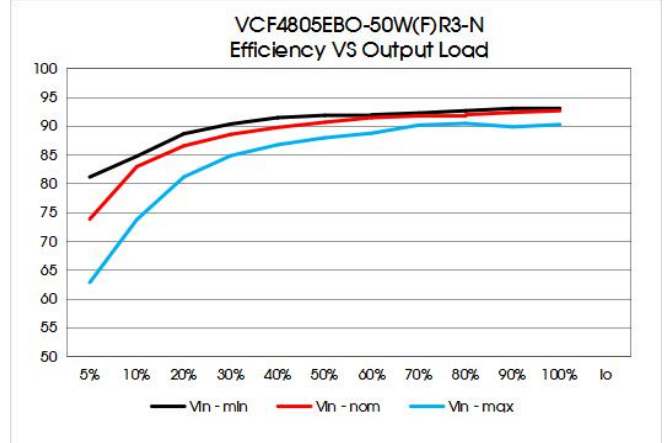
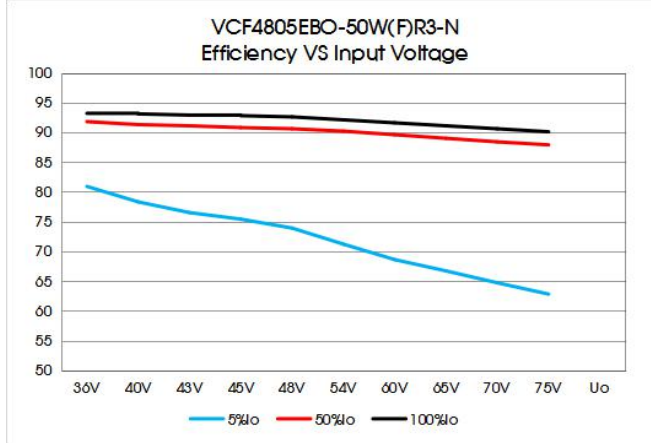

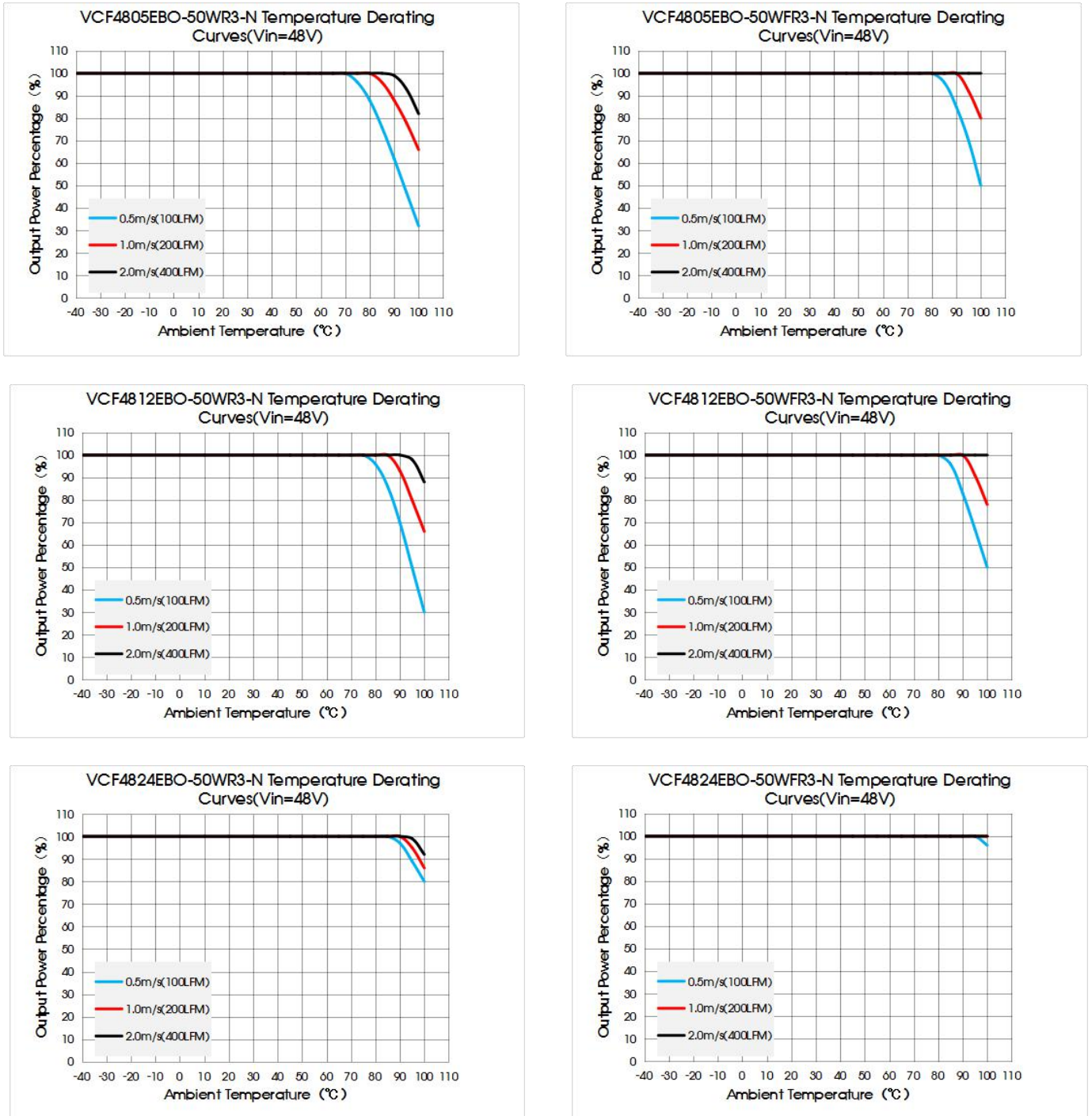

Fig. 1

## Remote Sense Application

### 1. Remote Sense Connection if not used

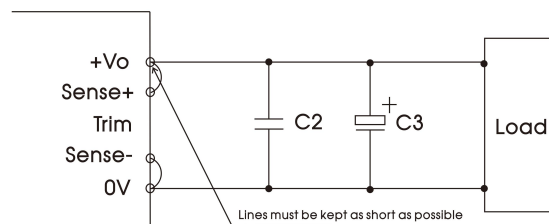

Fig. 2

Notes:

- (1) If the sense function is not used for remote regulation the user must connect the +Sense to +Vo and -Sense to 0V at the DC-DC converter pins and will compensate for voltage drop across pins only.
- (2) The connections between sense lines and their respective power lines must be kept as short as possible, otherwise they may be picking up noise, interference and/or causing unstable operation of the power module.

2. Remote Sense Connection used for Compensation

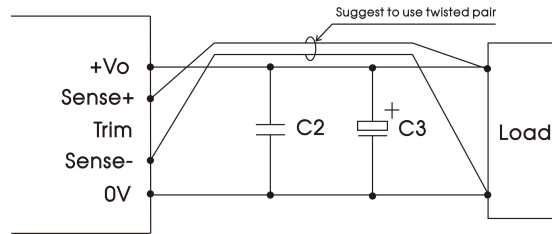

Fig. 3

Notes:

- (1) Using remote sense with long wires may cause unstable output, please contact technical support if long wires must be used.
- (2) PCB-tracks or cables/wires for Remote Sense must be kept as short as possible. Twisted pair or shielded wairs are suggested for remote compensation and must be kept as short as possible.
- (3) We recommend using adequate cross section for PCB-track layout and/or cables to connect the power supply module to the load in order to keep the voltage drop below 0.3V and to make sure the power supply's output voltage remains within the specified range.
- (4) Note that large wire impedance may cause oscillation of the output voltage and/or increased ripple. Consult technical support or factory for further advice of sense operation.

Design Reference

1. Ripple & Noise

All the DC-DC converters of this series are tested before delivery using the recommended circuit shown in Fig. 4.

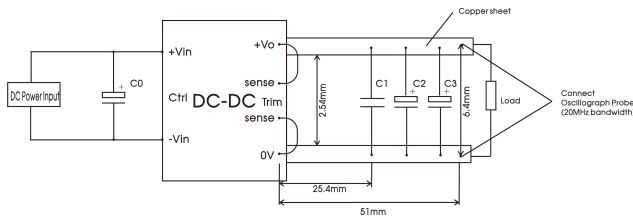

Fig. 4

Capacitors value	C0	C1	C2	C3
Output voltage				
05/12VDC	100µF/ 100V	1µF/50V	10µF/50V	330µF/63V
24VDC				470µF/35V

2. Typical application

All DC-DC converters of this series are tested before delivery using the recommended circuit shown in Fig. 5.

We recommended using Mornsun's EMC circuit, otherwise please ensure that at least a 100µF electrolytic capacitors is connected at the input in order to ensure adequate voltage surge suppression and protection.

Input and/or output ripple can be further reduced by appropriately increasing the input & output capacitor values Cin and Cout and/or by selecting capacitors with a low ESR (equivalent series resistance). Also make sure that the capacitance is not exceeding the specified max. capacitive load value of the product.



Fig. 5

Vout (VDC)	Cin	Cout
05/12	100µF/100V	330µF/63V
24		470µF/35V

3. EMC compliance recommended circuit

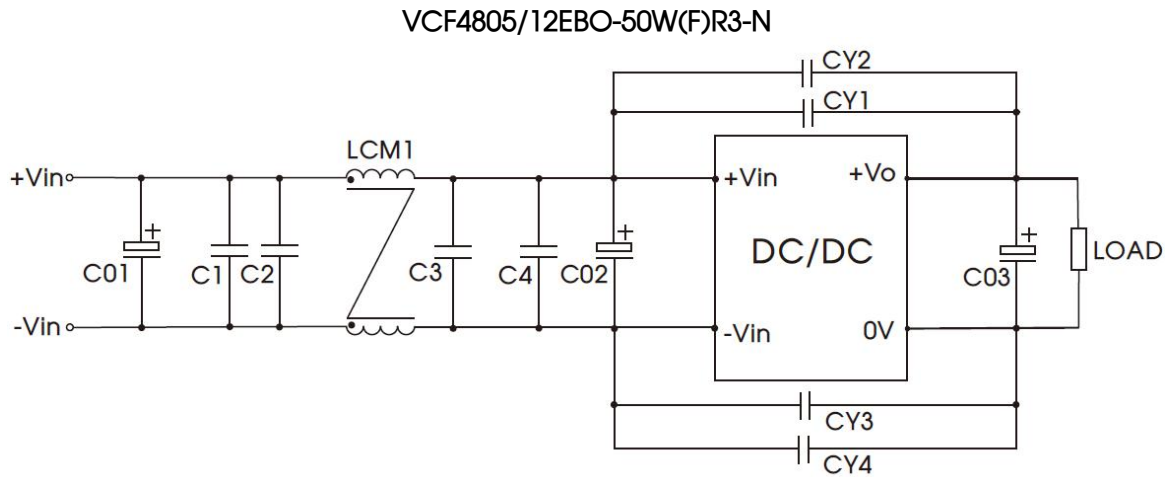

C01	470 $\mu$ F/100V (electrolytic capacitor)
C02	100 $\mu$ F/100V (electrolytic capacitor)
C03	330 $\mu$ F/63V (electrolytic capacitor)
C1, C2, C3, C4	4.7 $\mu$ F/100V
CY1, CY2, CY3, CY4	2.2nF/2KV
LCM1	2mH, recommended to use MORNSUN P/N: FL2D-A2-202(C)

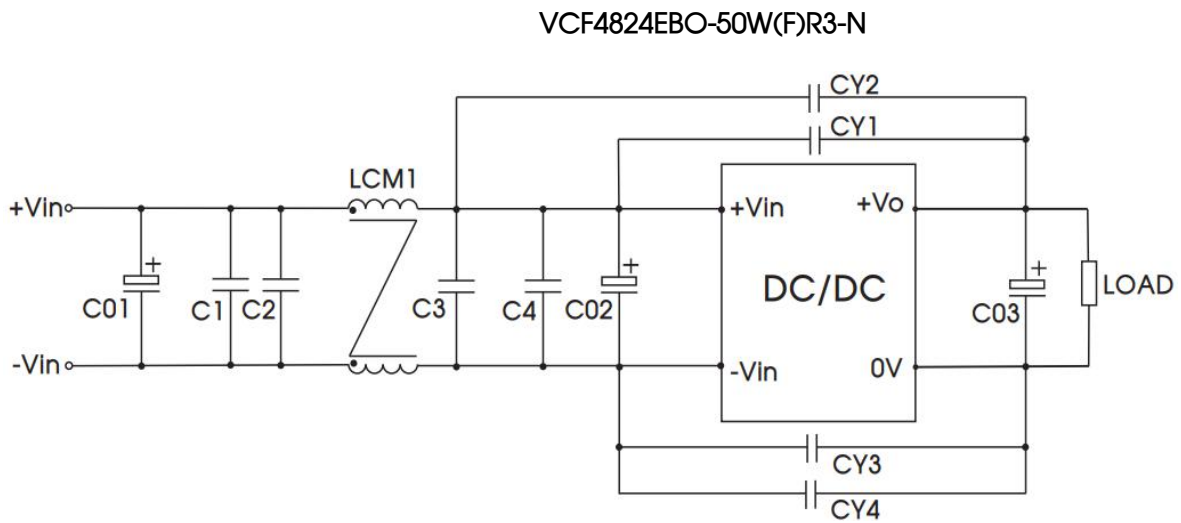

C01	470 $\mu$ F/100V (electrolytic capacitor)
C02	100 $\mu$ F/100V (electrolytic capacitor)
C03	330 $\mu$ F/63V (electrolytic capacitor)
C1, C2, C3, C4	4.7 $\mu$ F/100V
CY1, CY2, CY3, CY4	2.2nF/2KV
LCM1	2.0mH, recommended to use MORNSUN P/N: FL2D-A2-202(C)

Fig. 6-1

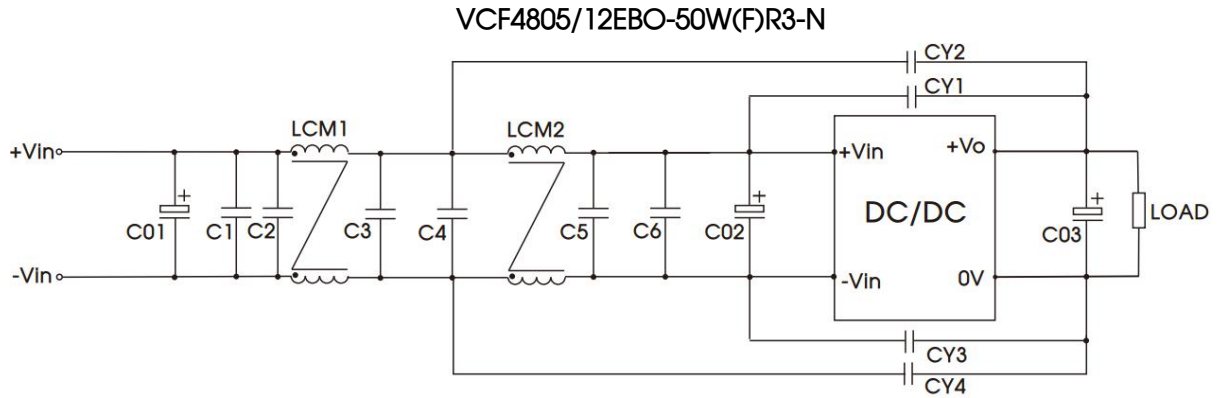

C01	470 $\mu$ F/100V (electrolytic capacitor)
C02	100 $\mu$ F/100V (electrolytic capacitor)
C03	330 $\mu$ F/63V (electrolytic capacitor)
C1, C2, C3, C4, C5, C6	4.7 $\mu$ F/100V
CY1, CY2, CY3, CY4	4.7nF/1.5KV
LCM1, LCM2	2.0mH, recommended to use MORNSUN P/N: FL2D-A2-202(C)

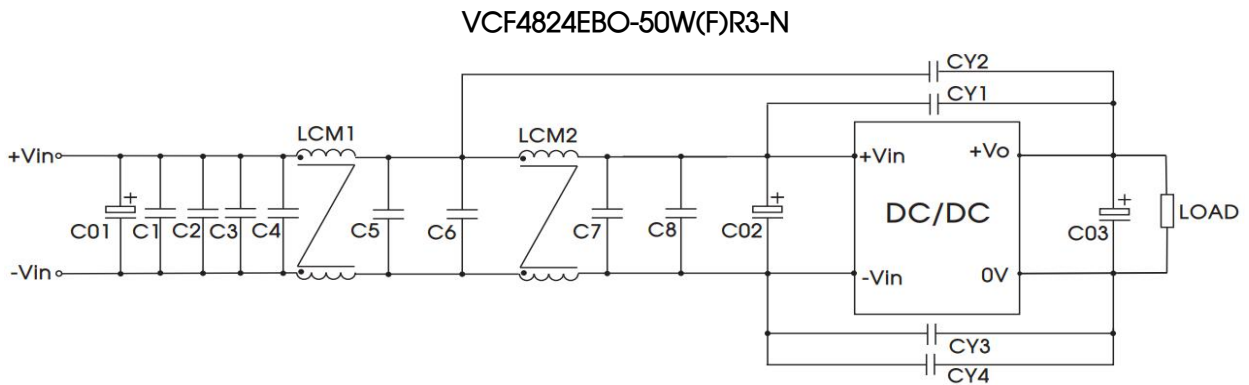

C01	470 $\mu$ F/100V(electrolytic capacitor)
C02	100 $\mu$ F/100V(electrolytic capacitor)
C03	330 $\mu$ F/63V(electrolytic capacitor)
C1, C2, C3, C4, C5, C6, C7, C8	4.7 $\mu$ F/100V
CY1, CY2, CY3, CY4	4.7nF/1.5KV
LCM1, LCM2	2.0mH, recommended to use MORNSUN P/N: FL2D-A2-202(C)

Fig. 6-2

4. Trim Function for Output Voltage Adjustment (open if unused)

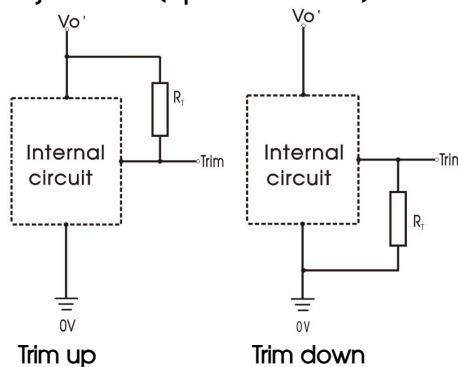

TRIM resistor connection (dashed line shows internal resistor network)

Calculating Trim resistor values:

Trim up

$$R_T = \left( \frac{5.11V_{nom}(100 + \Delta\%)}{1.225\Delta\%} - \frac{511}{\Delta\%} - 10.22 \right) (k\Omega)$$

Trim down

$$R_T = \left( \frac{511}{\Delta\%} \right) - 10.22 (k\Omega)$$

Note:

$R_T$  = Trim Resistor value

$$\Delta\% = \left| \frac{V_{nom} - V_{out}}{V_{nom}} \right| \times 100$$

$V_{nom}$  = nominal output voltage

$V_{out}$  = desired output voltage

When the output voltage is 12V, the up-regulated voltage is +10%, that is, the output voltage set to 13.2V:

$$\Delta\% = \left| \frac{12 - 13.2}{12} \right| * 100 = 10 \quad R_T = \frac{5.11 * 12 * (100 + 10)}{1.225 * 10} - \frac{511}{10} - 10.22 = 489K\Omega$$

When the output voltage is 12V, the down-regulated voltage is -10%, that is, the output voltage set to 10.8V:

$$\Delta\% = \left| \frac{12 - 10.8}{12} \right| * 100 = 10 \quad R_T = \frac{511}{10} - 10.22 = 40.88K\Omega$$

5. The products do not support parallel connection of their output

6. Recommended solution for thermal testing

During the application process, the thermal design of the product can be evaluated in combination with the temperature derating curve of the product, or it can be determined by testing the temperature at the hot test point in Fig. 7. It is a safe operating area for VCF405/12EBO-50(F)WR3-N, VCF4824EBO-50WFR3-N if the temperature lower than 125°C at point A. It is a safe operating area for VCF4824EBO-50WR3-N if the temperature lower than 130°C at point B.

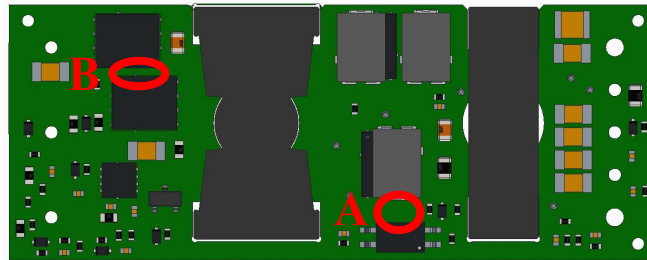

Fig. 7

7. For additional information please refer to DC-DC converter application notes on

[www.mornsun-power.com](http://www.mornsun-power.com).



VCF48\_EBO-50WR3-N Dimensions and Recommended Layout

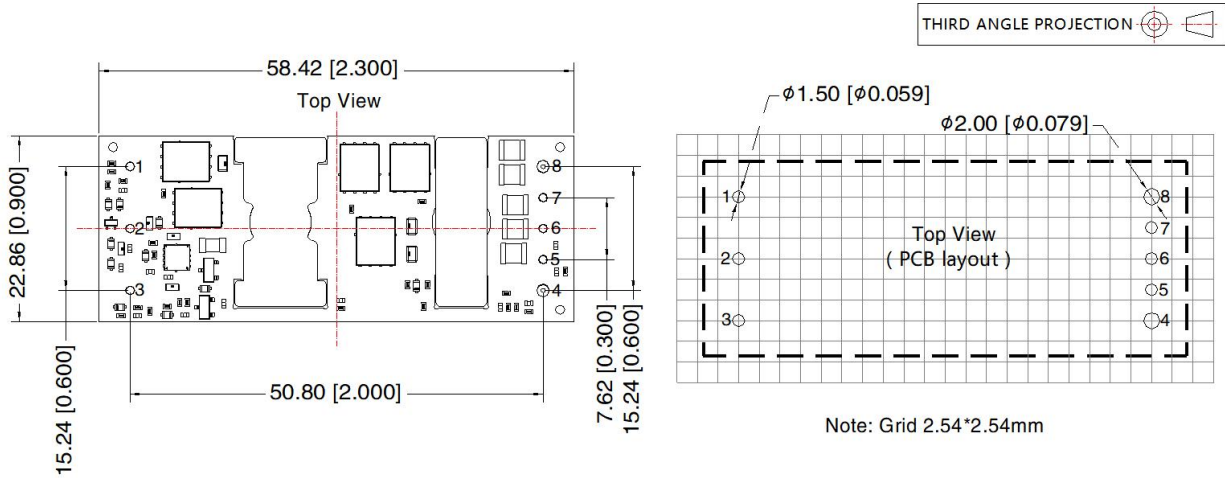

Note: Grid 2.54\*2.54mm

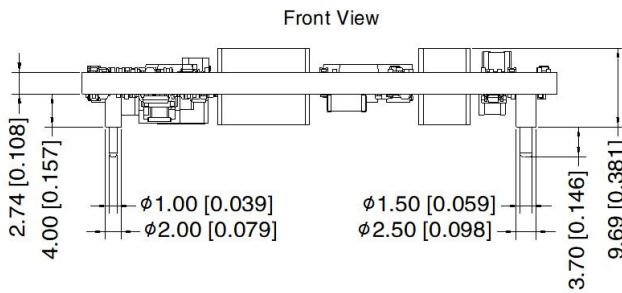

Pin-Out	
Pin	Mark
1	+Vin
2	Ctrl
3	-Vin
4	0V
5	-Sense
6	Trim
7	+Sense
8	+Vo

Note:  
Unit: mm[inch]  
Pin section tolerances:  $\pm 0.10[\pm 0.004]$   
General tolerances:  $\pm 0.50[\pm 0.020]$   
PIN1/2/3/5/6/7:  $\phi 1.0\text{mm}$ ; PIN4/8:  $\phi 1.5\text{mm}$   
The layout of the device is for reference only, please refer to the actual product

VCF48\_EBO-50WFR3-N Dimensions and Recommended Layout

THIRD ANGLE PROJECTION 

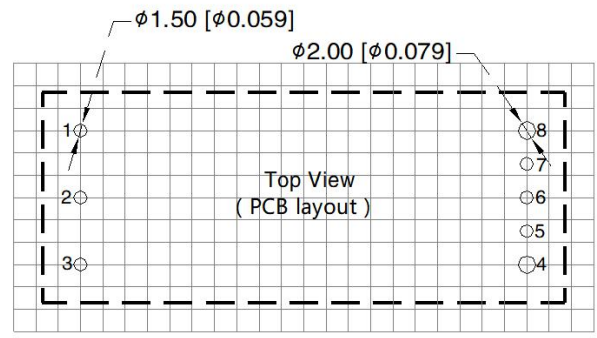
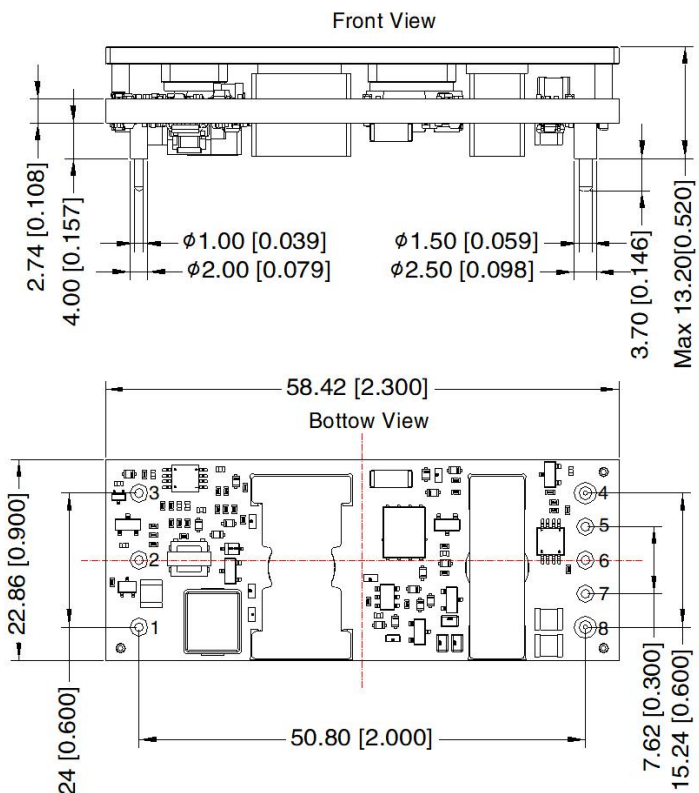

Note: Grid 2.54\*2.54mm

Pin-Out	
Pin	Function
1	+Vin
2	Ctrl
3	-Vin
4	0V
5	-Sense
6	Trim
7	+Sense
8	+Vo

Note:  
Unit: mm[inch]  
Pin section tolerances:  $\pm 0.10 [\pm 0.004]$   
General tolerances:  $\pm 0.50 [\pm 0.020]$   
PIN1/2/3/5/6/7:  $\phi 1.0\text{mm}$ ; PIN4/8:  $\phi 1.5\text{mm}$   
The layout of the device is for reference only, please refer to the actual product

Notes:

- For additional information on Product Packaging please refer to [www.mornsun-power.com](http://www.mornsun-power.com). Packaging bag number: 58210119(VCF48\_EBO-50WR3-N), 58210152(VCF48\_EBO-50WFR3-N);
- We suggest to use module at load of over 5%, if not, the ripple of the product may exceeds the specification, but does not affect the reliability of the product;
- The maximum capacitive load offered were tested at input voltage range and full load;
- Unless otherwise specified, parameters in this datasheet were measured under the conditions of  $T_a=25^\circ\text{C}$ , humidity<75%RH with nominal input voltage and rated output load;
- All index testing methods in this datasheet are based on company corporate standards;
- We can provide product customization service, please contact our technicians directly for specific information;
- Products are related to laws and regulations: see "Features" and "EMC";
- Our products shall be classified according to ISO14001 and related environmental laws and regulations, and shall be handled by qualified units.

Mornsun Guangzhou Science & Technology Co., Ltd.

Address: No. 5, Kehui St. 1, Kehui Development Center, Science Ave., Guangzhou Science City, Huangpu District, Guangzhou, P. R. China  
Tel: 86-20-38601850 Fax: 86-20-38601272 E-mail: [info@mornsun.cn](mailto:info@mornsun.cn) [www.mornsun-power.com](http://www.mornsun-power.com)