

SCM1212A Transformer Driver for Isolated Power Supplies

Features

- 4.5~8V Wide input voltage
- Push-Pull Driver for Small Transformers
- Two built-in power MOSFET and Highly symmetrical drive
- Built in soft start function
- Output short circuit protection
- Over temperature protection

Application

- DC-DC Isolation Converter
- Isolated Interface Power Supply for CAN,RS-485,RS-422,RS-232,SPI,I2C,Low-Power LAN.
- Industrial Automation
- Process Control
- Medical Equipment

Description

The SCM1212A is a oscillator power-driver integrated with MOSFET,specifically designed for small form factor,isolated power supplies in isolated interface applications.The SCM1212A drives a low-profile,center-tapped transformer primary from a 4.5~8V wide DC power supply.The secondary can be wound to provide any isolated voltage based on transformer turns ratio when V_{VD1}/V_{VD2} is less than absolute maximum rating.

The driver of internal MOSFETs is highly symmetrical,thereby decreasing the degree of magnetic biasing of push-pull topology.The chip also is integrated with three key technologies to improve reliability:soft start,output short circuit protection,and over temperature protection.

The SCM1212A is available in a small SOT23-5 package,and is specified for operation at temperatures from -40°C to 125°C.

Packaging

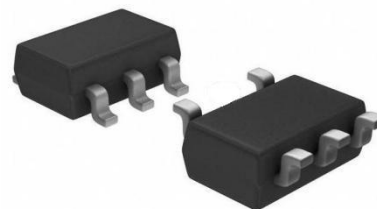

Optional Packaging of Product:SOT23-5 please refer to "Order Information" for details of silk screen.

Simplified Schematic

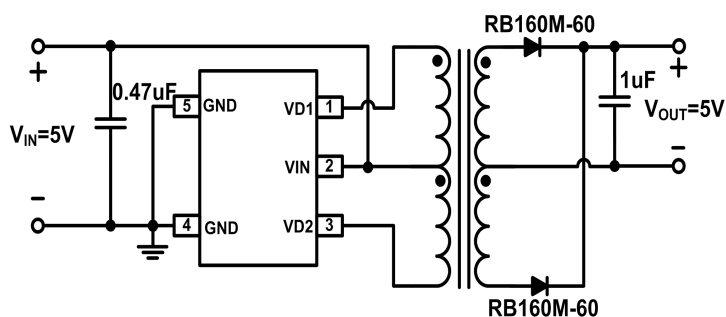

Function Curves

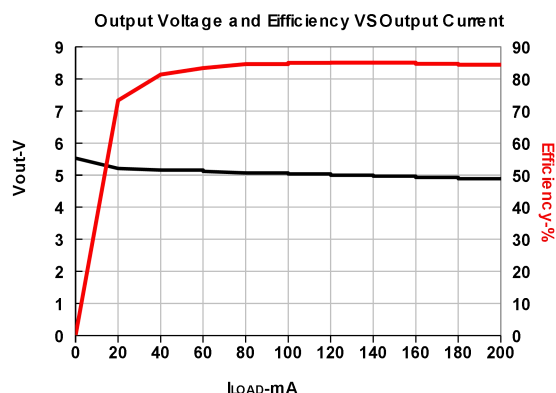

Contents

1	Title Page.....	1	3.5	Switch Characteristics.....	4
1.1	Features and Packaging.....	1	4	Characteristic Curves.....	4
1.2	Application.....	1	4.1	Typical Curves.....	4
1.3	Function Description.....	1	4.2	Parameter Measurement Information.....	5
1.4	Typical Application Circuit and its Function Curves1		5	Features Description.....	6
2	Pin Packaging and Description.....	2	6	Product Operation Mode.....	6
3	IC Parameters.....	3	7	Extended Output Design.....	8
3.1	Limit Rated Value.....	3	8	Application Circuit.....	8
3.2	Recommended Operation Parameters.....	3	9	Suggestions of Power Use.....	8
3.3	Thermal Resistance Information.....	3	10	Order, Packaging and Packing.....	9
3.4	Electrical Property.....	3			

Pin Configuration

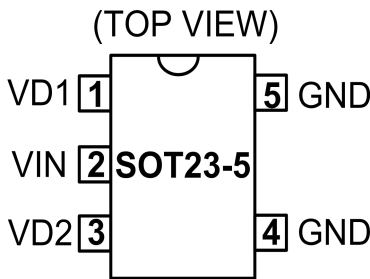

Inter Block Diagram

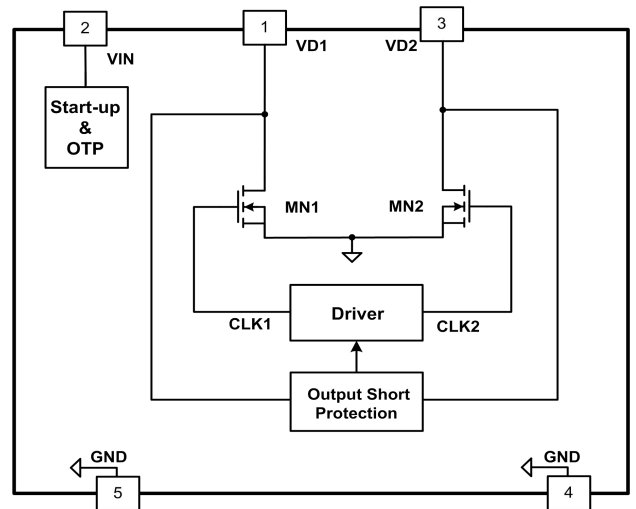

Pin Description

Name	I/O	Description
VIN	P	Supply voltage input. Connect this pin to the center-tap of the transformer primary side. Buffer this voltage with a 1 μ F to 10 μ F ceramic capacitor
VD1	O	Open Drain output 1. Connect this pin to one end of the transformer primary side
VD2	O	Open Drain output 2. Connect this pin to the other end of the transformer primary side.
GND	I	Device ground. Connect this pin to board ground. In application, it is better to connect the pin 1 and pin 3 together with the device with good heat dissipation performance, so that the internal heat of chip can be quickly conducted out.
GND	I	

Absolute Maximum Ratings

General test conditions: Free-air, normal operating temperature range (unless otherwise specified).

Parameters		Min	Max	Unit
Input Voltage	V_{VIN}	-0.4	10	V
Drain Voltage of MOSFET	V_{VD1}/V_{VD2}	-0.7	27	V
Drain Peak Current of MOSFET	I_{D1P}, I_{D2P}		600	mA
Operation Junction Temperature Range	T_J	-40	150	$^{\circ}$ C
Storage Temperature	T_{STG}	-55	150	
Temperature of Lead with the distance of 0.6mm from the shell within 10 seconds			260	
Moisture Sensitivity Level	MSL	MSL3		
Rated Value of ESD	HBM		2000	V
	CDM		1000	
Continuous Power Dissipation	P_{TOT}		270	mW

Note: if the value exceeds the stress value listed in the table's "maximum value", it may cause permanent damage to the components. If the product operates in the maximum rated condition for a long time, the reliability of the components may be affected. All voltage values take GND as basis reference. The current refers to the current between positive input and negative output of the specified terminal.

Recommended Operating Conditions

Unless otherwise specified, the following parameters are measured in the conditions of $V_{VIN}=5V$.

Parameters		Min	Max	Unit
Input Voltage	V_{VIN}	4	8	V
Drain Voltage of MOSFET	V_{VD1}/V_{VD2}	-0.7	20	V
Output Switching Current of Primary Winding	I_{D1}, I_{D2}		350	mA
Operation Junction Temperature	T_J	-40	125	°C

Thermal Resistance Information

Heating current is 1A and heating time is 300s, test current is 10mA and test time is 300s.

Junction-to-ambient thermal resistance	θ_{JA}	200	°C/W
--	---------------	-----	------

Note: Because SOT23-5 has small packaging size, thermal resistance between components and board θ_{JB} and thermal resistance between components and shell θ_{JC} have no reference value for system design. The reference standard is JESD51-1.

Electrical Characteristics

Unless otherwise specified, $V_{VIN}=5V$ and the environment temperature is 25°C.

Symbol	Corresponding Parameters	Test Conditions	Min	Typ	Max	Unit
Supply Section (VIN Pin)						
I_{RUN}	Operating Current of Chip	$V_{VIN}=5V$	0.4	0.8	1.2	mA
I_{START}	I_{VIN} when V_{VIN} is in under-voltage lockout	$V_{VIN}=3V$		1.26		mA
V_{VIN_ON}	Start-up Voltage	V_{VIN} voltage increasing	3.4	3.7	4	V
V_{VIN_OFF}	Voltage when V_{VIN} is in under-voltage lockout	V_{VIN} voltage decreasing	2.7	3	3.3	V
T_{OTP}	Temperature of Over-temperature Protection			162		°C
T_{OTPH}	Return Difference of Over-temperature Protection			32		°C
Drain Port of MOSFET (VD1/VD2 Pin)						
$B_{V_{DSS}}$	Breakdown Voltage of MOS Transistor	$V_{VIN}=0V, I_{DS}=100\mu A$	27	43		V
R_{DS_ON}	On Resistance ($V_{VIN}=5V$)	$T_J=25^\circ C, I_{DS}=0.2A$		0.38	1.5	Ω
		$T_J=100^\circ C, I_{DS}=0.2A$		0.47		
R_{DS_ON}	On Resistance ($V_{VIN}=4V$)	$T_J=25^\circ C, I_{DS}=0.2A$		0.43		Ω
		$T_J=100^\circ C, I_{DS}=0.2A$		0.53		
I_{SOFT}	Current of Soft Start	$V_{VD1}=V_{VD2}=3V$	350	475	600	mA
Internal Time						
F_{OSC}	Operating Frequency		246	273	300	kHz
T_{D_OSP}	Delay Time of Short Circuit Protection	$F_{OSC}=250kHz$		100		ms
T_{SLEEP}	Sleep Time of Short Circuit Protection	$F_{OSC}=250kHz$		800		ms

Switch Characteristics

Unless otherwise specified, $V_{VIN}=5V$ and the environment temperature is 25°C.

Symbol	Corresponding Parameters	Test Conditions	Min	Typ	Max	Unit
t_r	VD1, VD2 output rise time	$V_{VIN}=5V$, See Figure 9		20		ns
t_f	VD1, VD2 output fall time	$V_{VIN}=5V$, See Figure 9		10		ns
t_{BBM}	Break-before-make time	$V_{VIN}=5V$, See Figure 9		100		ns

Typical Performance Curves

Unless otherwise specified, the following typical characteristic curves are obtained in the conditions of $V_{VIN}=5V$ and $T=25^{\circ}C$. TP1 curve is obtained by testing the test circuit shown in Figure 7.

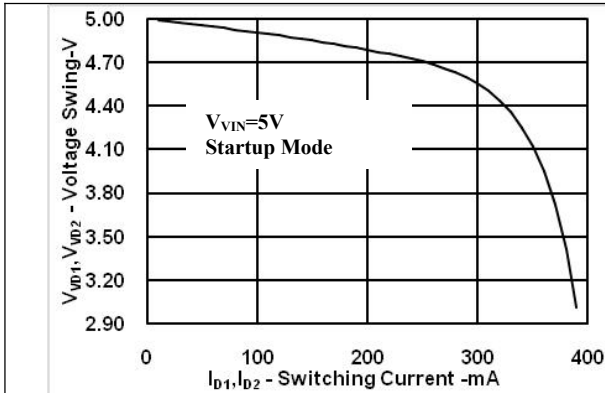

Figure 1 Drain Voltage of MOS Transistor VS. Switching Current of Primary Winding (Start Mode)

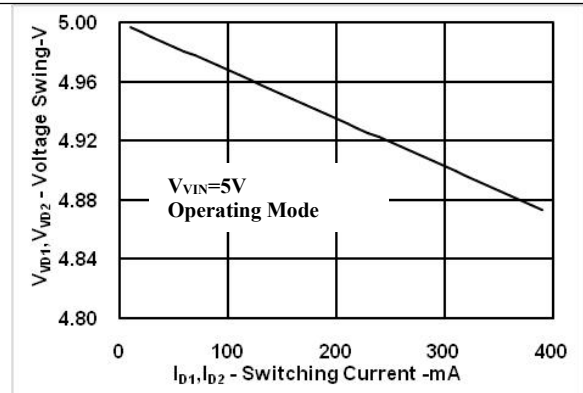

Figure 2 Drain Voltage of MOS Transistor VS. Switching Current of Primary Winding (Steady State Mode)

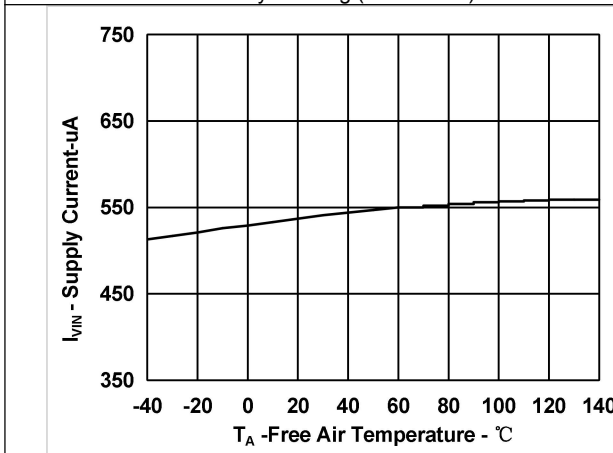

Figure 3 Average Supply Current of VIN VS Free Air Temperature

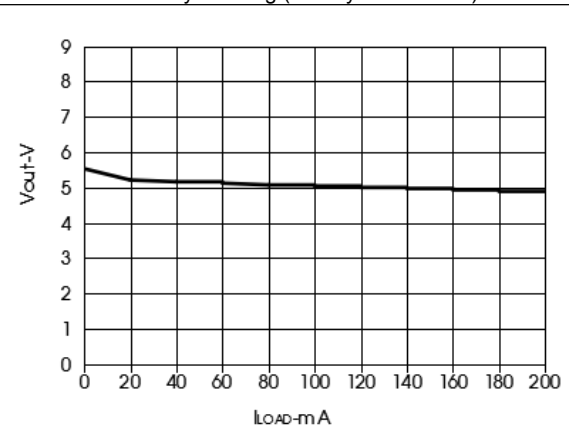

Figure 4 Relationship between Output Voltage and Load Current

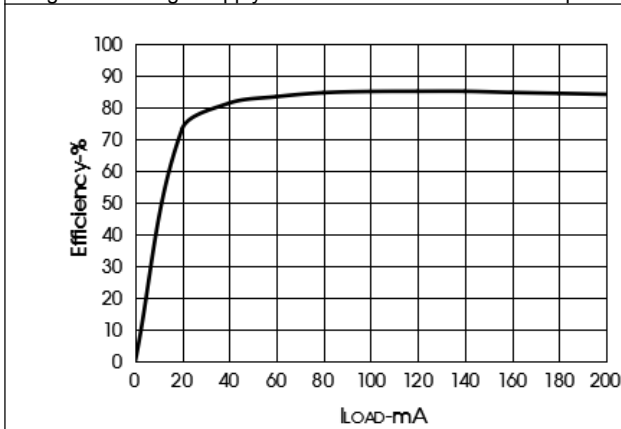

Figure 5 Efficiency and Load Current

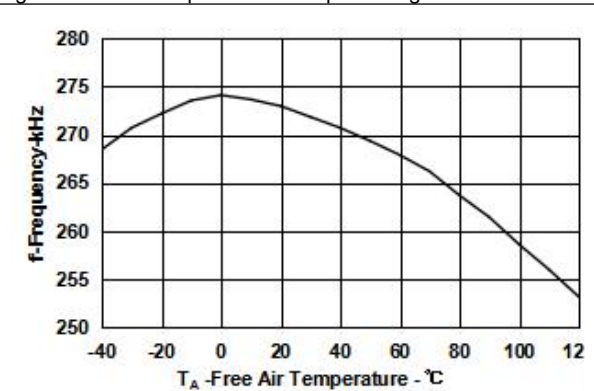
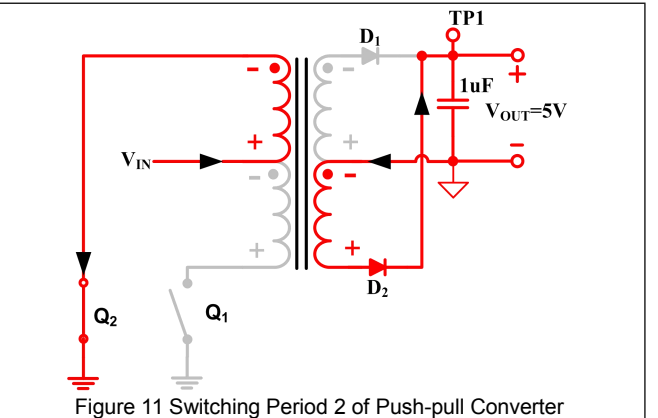
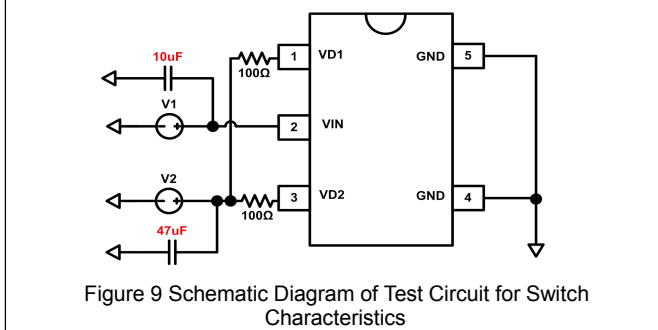
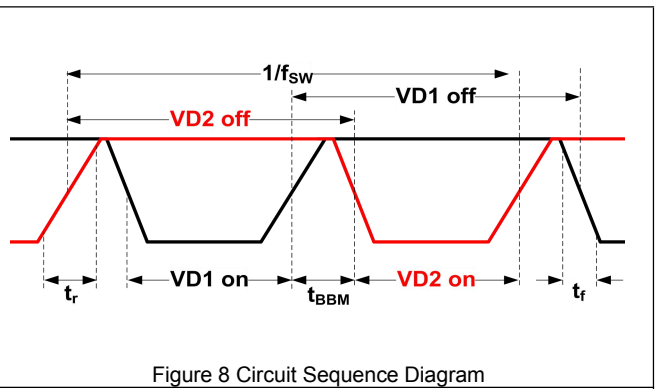
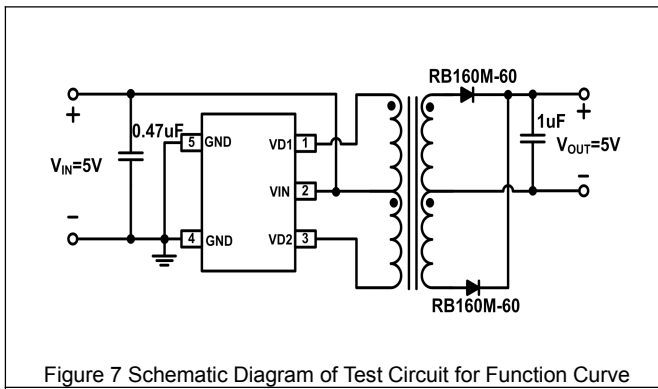

Figure 6 Switching Frequency of MOS Transistor VS Free Air Temperature



(1) Push-pull Converter

As shown in Figure 10 and Figure 11, the push-pull converter is a transformer with center tap, which can achieve the transmission of energy from the primary winding to secondary winding.

The drive waveform of drains VD1 and VD2 of two MOSFETs Q1 and Q2 are shown in Figure 8. Two MOS transistors are on alternatively and the times of the breakover periods of two transistors are equal, and there is a short period t_{BBM} between the two breakover periods that the two power transistors are not on. That is to say, the drive levels of two MOS transistors are quasi complementary in time sequence, that is the other transistor is off when one transistor is on, but there is a short period of dead time during the switch to prevent the backward current flow when two the transistors are not on simultaneously. As shown in red highlighted parts in Figure 10, when Q1 is on, input voltage V_{IN} drives a current which arrives at the reference ground through the lower half of primary winding of transformer and Q1, and at the same time, the induced electromotive force of side winding charges output capacitor through diode D1. Similarly, as shown in Figure 11, when Q2 is on, the induced electromotive force charges output capacitor through diode D2. As continuously repeating the above process, the secondary winding of power converter obtain the needed power supply.

(2) Magnetization of Magnetic Core

Figure 12 is the ideal magnetization curve of push-pull converter, and the vertical axis represents magnetic flux density B and the horizontal axis represents magnetic field intensity H. When Q1 is on, the magnetic flow is pushed to point A' from point A. Similarly, when Q2 is on, the magnetic flow is then pulled back to point A from point A'. The magnetic flux density B is proportional to the product of voltage of primary winding V_{LP} and breakover time of MOS transistors t_{ON} , which can be described in the following formula:

$$B \approx V_{LP} \times t_{ON}$$

The volt-second product $V_{LP} \times t_{ON}$ defines the magnetization degree of each switching period. If the volt-second products in the above “push” and “pull” periods are not identical, a small direct current component may be generated to cause the deviation of magnetic flow. If balance cannot be restored, the deviation of magnetic flow will gradually increase in the each of the following switching period, making magnetic core become saturated gradually. The phenomenon of the deviation of magnetic flow is usually caused by the unequal on resistance or switching speed of two power switching components. Although the on resistance or switching speed of the two power components are approximately equal through integrating them into the same wafer with the help of high matching advantage of semiconductor integrated circuit technology, the manufacturing error still exists, causing the small deviation for the breakover time.

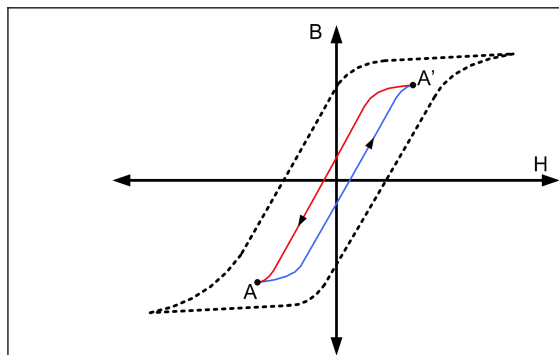

Figure 12 Magnetization Curve

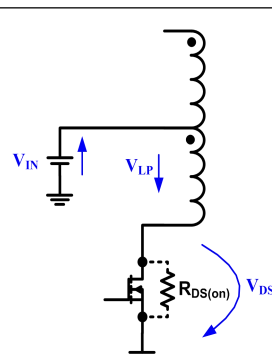

Figure 13 Self-adapting Positive Temperature Coefficient Rds(on)

Fortunately, the on resistance $R_{DS(on)}$ of MOSFET has positive temperature coefficient, with which SCM1212A has the self-correcting effect to restrain the imbalance of volt-second. Under the condition that there is small deviation between the breakover time of two MOS transistors, the transistor which has longer breakover time t_{ON} generates more quantity of heat, and the temperature of the transistor rises to improve $R_{DS(on)}$, then in the breakover period when the load remains unchanged, the drain-source voltage of this transistor V_{DS} is relatively high, as shown in Figure 13, the voltage of primary winding V_{LP} conforms to the formula $V_{LP} = V_{IN} - V_{DS}$, thus the V_{LP} of the transistor which has larger t_{ON} will gradually decrease to make volt-second recover balance.

Product Operation Mode

SCM1212A has three operation modes, which respectively are start-up mode, operation mode and short mode.

In start-up mode, SCM1212A provides sufficient charging time for output capacitor, to avoid the abnormal start caused by output short circuit which is incorrectly identified due to the excessive low voltage of output capacitor when it is just started, at the same time, the MOS transistor in start-up mode is always operating in current-limiting drive status which means that the drive voltage of MOS transistor in start is limited, thereby making the current flowing through MOS transistor restrained within the safe range of components, that is to restrain the output switching current of primary winding to I_{SOFT} to achieve the soft start of the system, thereby avoiding the over-current impact and the generation of excessive heat.

In operation mode, MOS transistor is always in full drive status which means that the MOS transistor is operating in switching status and the breakover voltage is very low, which guarantee the efficiency of converter.

In short mode, it will stop driving the converter in sleep mode and the heat generated in start-up mode will be dissipated, then the product changes to start-up mode.

The three operation modes can be freely switched. Only when there is abnormality of output short circuit, the product will repeatedly switch between the start-up mode and short mode, when the abnormality disappears, the product will automatically change to operation mode, all of which can fully guarantee the reliability of converter and have no influence on the performance of converter in normal operation.

Start-up Mode

The voltage of output capacitor is zero when the converter is just started, and the converter is firstly in start-up mode. The flow diagram is shown in Figure 14, that is, start → Drive the selected MOS transistor in current-limiting drive method → check the switch-on voltages of MOS transistors (V_{VD1} , V_{VD2}) → judge whether the voltages (V_{VD1} , V_{VD2}) are more than the set value.

If (V_{VD1} , V_{VD2}) are more than the set value, then calculate the duration of over-voltage → judge whether the duration is more than T_{D_OSP} (100ms, typ.). If yes, then the system turns into short circuit mode, if no, then the above process is repeated.

If (V_{VD1} , V_{VD2}) are not more than the set value, then the system turns into operation mode.

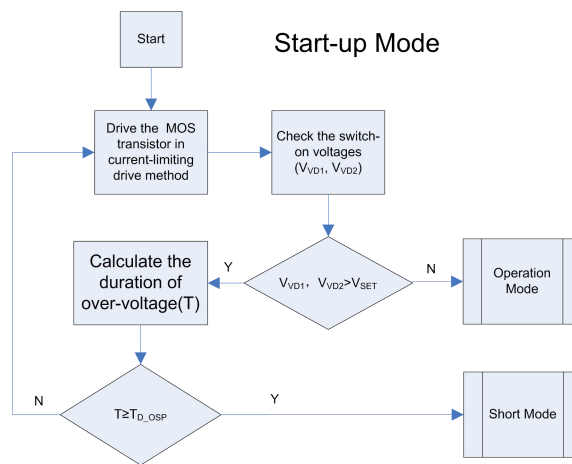

Figure 14 Flow Diagram of Start-up Mode

Operation Mode

If the output of converter has no short circuit, the voltage of output capacitor, in start-up mode, will gradually increase during the continuously circular charging. When the breakover voltage of MOS transistor is less than or equal to the set value, the converter will turn into operation mode. The flow diagram is shown in Figure 15, that is, determine that the breakover voltage of MOS transistor is less than or equal to the set value → drive the selected MOS transistor with full drive → check the switch-on voltage of MOS transistors → judge whether the voltages (V_{VD1}, V_{VD2}) are more than the set value.

If the breakover voltage of MOS transistor is more than the set value, then the system goes into time-counting cycle of start-up mode, otherwise, the system turns back to the step “drive the selected MOS transistor with full drive”, and the above processes are repeated, which is the normal operation of the converter after the product is started. In the operation, MOS transistor is fully driven, that is the MOS transistor is operating in switching status and the on resistance is low, resulting in low energy consumption and high efficiency.

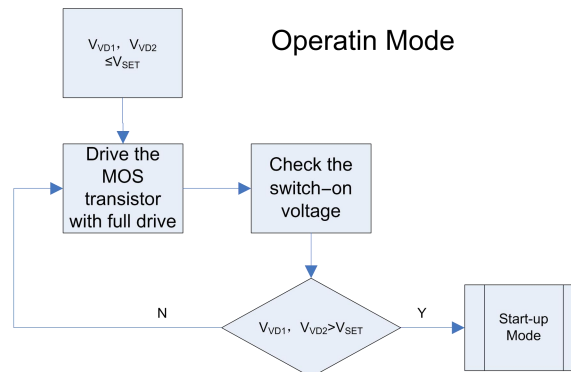

Figure 15 Flow Diagram of Operation Mode

Short Mode

If the output of the converter has short circuit, it will detect in start-up mode that the breakover voltage of MOS transistor is more than the set value, then the accumulated over-voltage time will definitely exceed T_{D_OSP} (100ms, typ.). At this time, SCM1212A will stop to drive the MOS transistor and begin to count the time of stopping driving MOS transistor. When the time is counted to T_{SLEEP} (800ms, typ.), the product resumes operation and turns into start-up mode.

The flow diagram of short mode is shown as Figure 16: determine the duration of over-voltage exceeding T_{D_OSP} → stop driving and begin to count time (sleep mode) → finish counting time → turn back to start-up mode. We can see that if the converter is always in output short circuit status, it will operate in the short mode and start-up mode alternately.

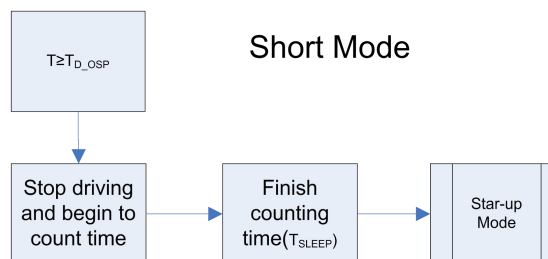
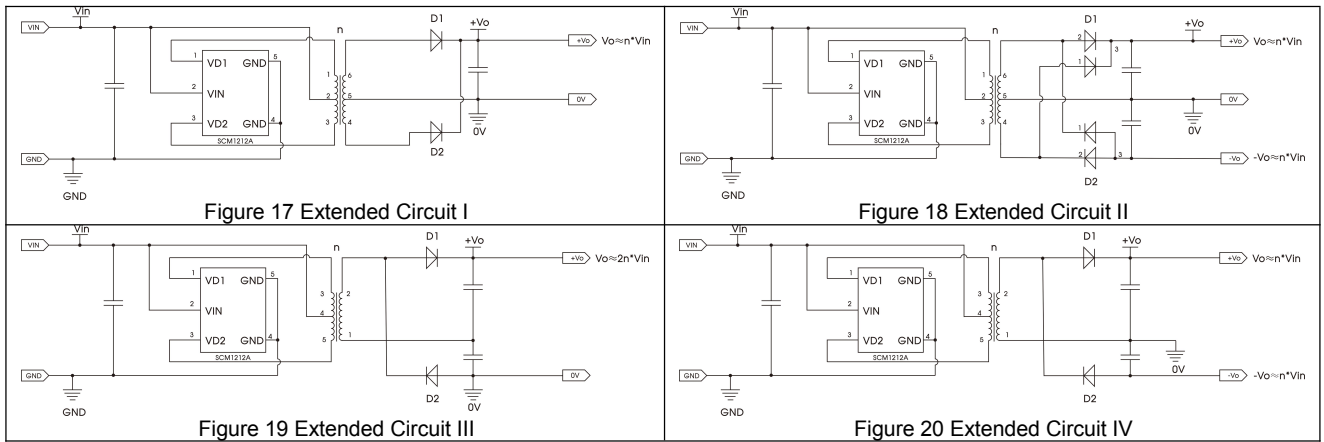

Figure 16 Flow Diagram of Short Mode

SCM1212A chip is used to drive the push-pull circuit, which can make output voltage become higher.



Extended Circuit I and Extended Circuit II output rectification is a full-wave rectification method, wherein the Extended Circuit I is a single output, the Extended Circuit II is a two-way output, the full-wave rectification is made up of complex side winding, but its output ripple is smaller than the double-pressure rectification.

Extended Circuit III and Extended Circuit IV output rectification is a double-pressure rectification method, wherein the Extended Circuit III is a single output, the Extended Circuit IV is a two-way output, the double-pressure rectification is just made up of simple side winding, but its output ripple is larger than the full-wave rectification.

Application Circuit

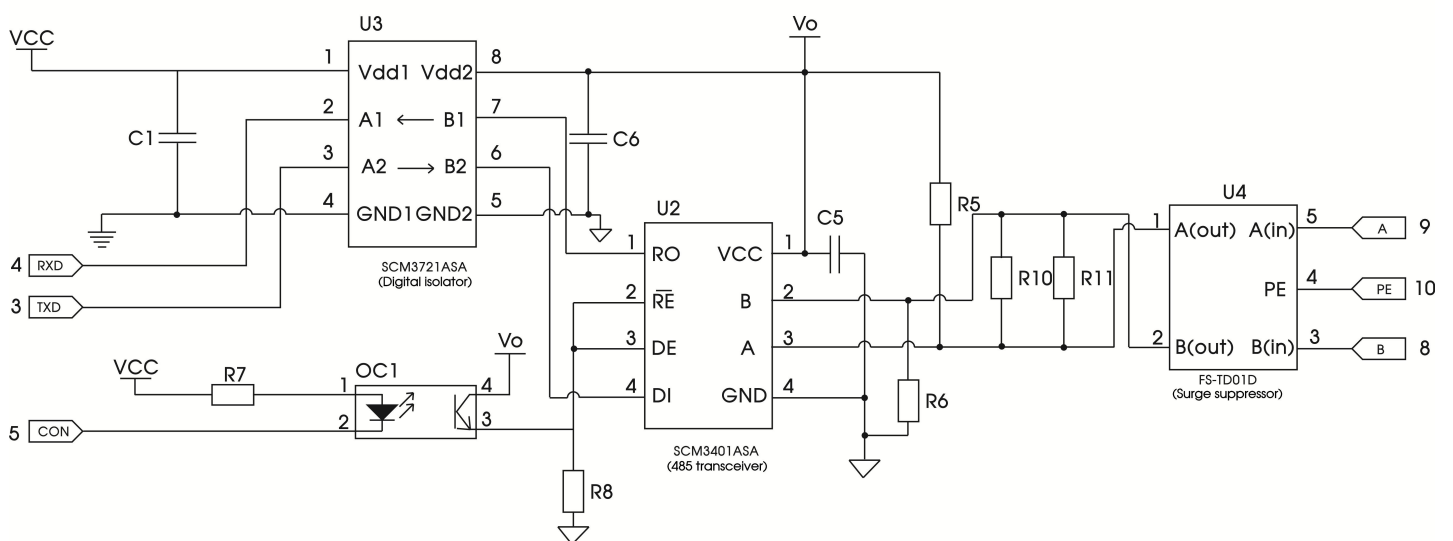
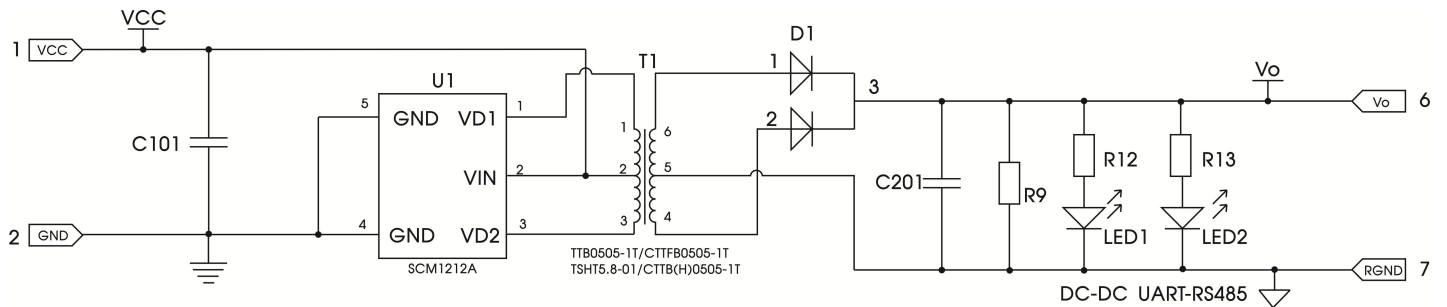

Figure 21 Application Circuit I

(1) Introduction of TTB05xx-1T Transformer

With the voltage of primary winding and secondary winding of 1650VDC,the allowable working temperature of -40℃~+125℃ and the packaging size of 6.50 x 8.80 x 3.60mm,combined with design of our ICSCM1212ATA product,TTB05xx-1T transformer can be used for electrical isolation scenario which is applicable to 5VDC input and output power less than 1W,such as digital circuit,analog acquisition circuit and data exchange circuit.Please log in the official website of Mornsun and contact the salespeople to obtain the specific specification.

(2) Introduction of TSHT5.8-01 Transformer

TSHT5.8-01 transformer,with the packaging size of 12.50 x 8.70 x 5.90mm,is specially designed for use with IC.It is mainly used for the electrical isolation scenario which is applicable to 5VDC input and 5VDC output power less than 1W,such as digital circuit,analog acquisition circuit and data exchange circuit.

Suggested Use of Power Supply

If the input power is not stable enough,it is suggested to add 1uF capacitor in the first section of IC SCM1212A,if there is high requirement to EMI performance,add capacitor and inductor in the first section of the module to filter noise,if there is high requirement to no-load voltage,add resistor after the filtering capacitor of the module as dummy load,it is suggested that the connecting wire of pin 1 and pin 3 to the transformer is as short as possible. It is suggested that the connecting wire of pin 4 and pin 5 as short as possible.

Ordering information

Product Model	Packaging	Quantity of Pin	Silk Screen	Packing
SCM1212ATA	SOT23-5	5	1212YM	3K/tray

Description of Product Model

SCM1212XYZ:

- (1) SCM1212,product code.
- (2) X = A-Z,version code.
- (3) Y = T,packaging code,T: SOT packaging.
- (4) Z = C,I,A,M,code of temperature rangeC: 0℃-70℃,I: -40℃-85℃,A: -40℃-125℃,M: -55℃-125℃.

Description of Silk Screen

1212YM:

- (1) 1212,code of product silk screen in 4 digits.
- (2) YM,Product Traceability Code.

Silk Screen Information

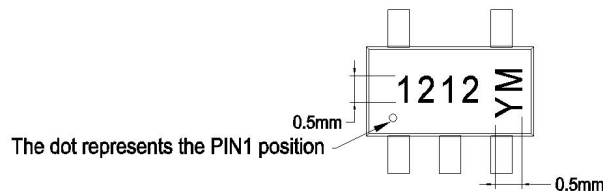

Note:

- 1、Typeface: Arial;
- 2、Character size:
Height: 0.5mm, Spacing: 0.1mm

THIRD ANGLE PROJECTION 

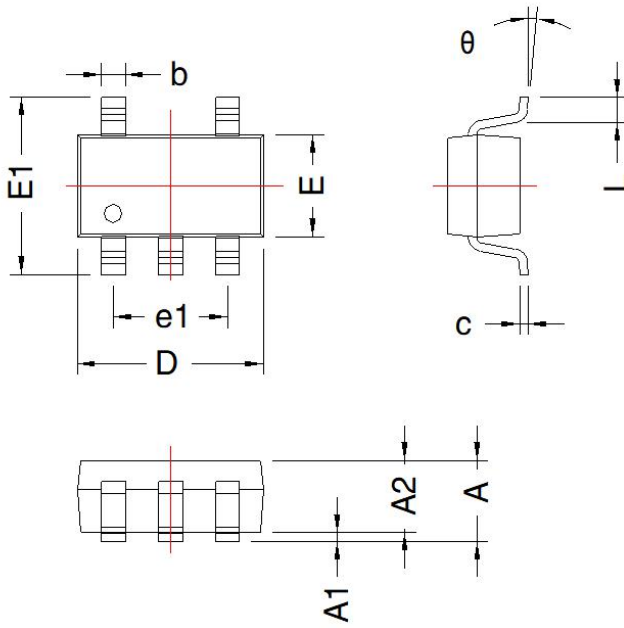

SOT-23-5				
Mark	Dimension(mm)		Dimension(inch)	
	Min	Max	Min	Max
A	1.05	1.25	0.041	0.049
A1	0	0.1	0	0.004
A2	1.05	1.15	0	Min
D	2.82	3.02	0.111	0.119
E	2.65	2.95	0.104	0.116
E1	1.5	1.7	0.059	0.067
L	0.3	0.6	0.012	0.024
b	0.3	0.5	0.012	0.02
e	0.95 TYP		0.037 TYP	
e1	1.8	2	0.071	0.079
c	0.3	0.6	0.012	0.024
theta	0°	8°	0°	8°

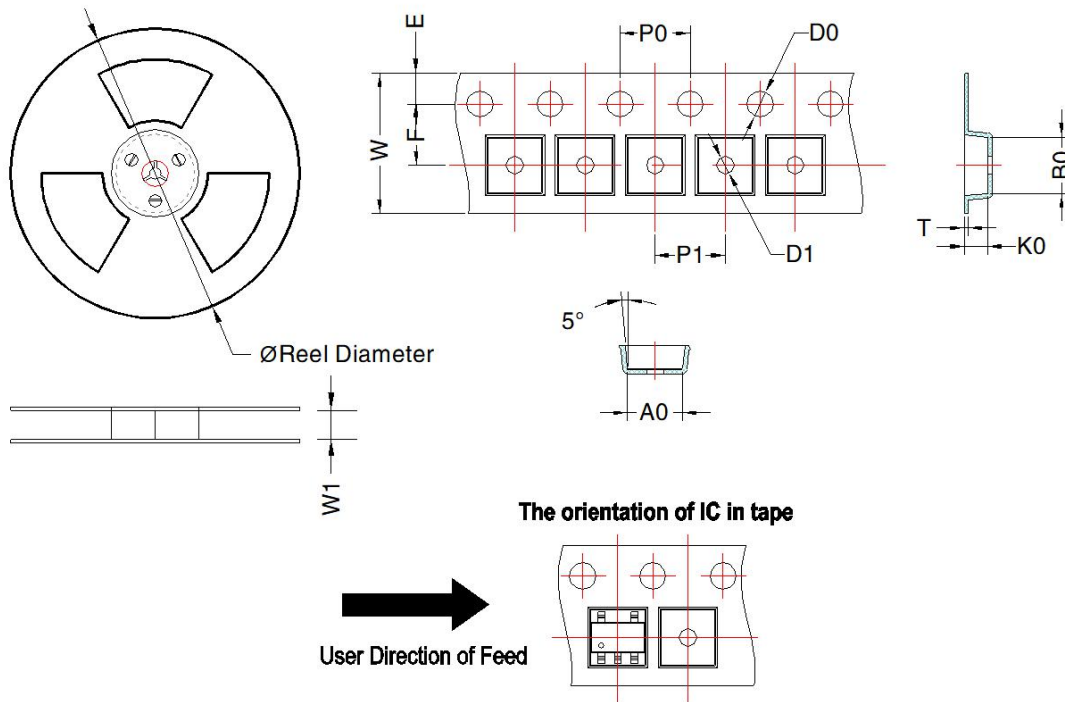

Device	Package Type	MPQ	Reel Diameter (mm)	Reel Width W1 (mm)	A0 (mm)	B0 (mm)	K0 (mm)	T (mm)	W (mm)	E (mm)	F (mm)	P1 (mm)	P0 (mm)	D0 (mm)	D1 (mm)
SCM1212ATA	SOT-23-5	3000	180.0	8.5	3.17	3.23	1.37	0.25	8.0	1.75	3.5	4	4	1.5	1.0

Mornsun Guangzhou Science & Technology Co.,Ltd.

Address: No.5,Kehui St.1,Kehui Development Center,Science Ave.,Guangzhou Science City,huangpu District,Guangzhou,P.R.China

Tel: 86-20-38601850

Fax: 86-20-38601272

Email: sales@mornsun.cn