

## TD(H)341S485S-FT DFN package isolated RS485 Transceiver

### Features

- Ultra-small, ultra-thin, chip scale DFN package
- Compliant with TIA/EIA-485A standard
- Integrated isolated 3.3V power
- I/O power supply range supports 3.3V and 5V microprocessors( Specific application refer to “ Recommendations ②” )
- High isolation to 5000VDC (TD341S485S-FT 3000VDC)
- Bus-Pin ESD protection up to 15kV(HBM)
- Baud rate up to 20Mbps
- >25kV/us CMTI
- Low communication delay
- Full-duplex
- 1/8 unit load—up to 256 nodes on a bus
- Bus fail-safe
- Bus driver short circuit protection
- Industrial operating ambient temperature range: -40°C to +105°C
- Meet AEC-Q100 standards
- Moisture Sensitivity Level (MSL) 3

### Package

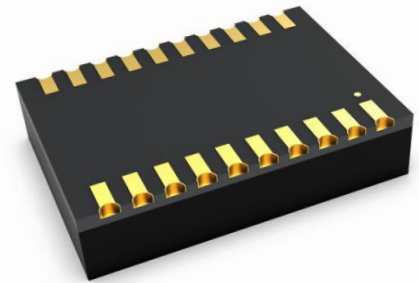

### Applications

- Industrial Automation
- Building Automation
- Smart Electricity Meter
- Remote Signal Interaction, Transmission

### Functional Description

TD(H)341S485S-FT is a full-duplex enhanced transceiver designed for RS-485 data bus networks, which is fully compliant with TIA/EIA-485A standard and is suitable for data transmission of up to 20 Mbps. Their logic side supports 3.3V and 5V logic level conversion. Receivers have an exceptionally high input impedance, which places only 1/8 of the standard load on a shared bus and up to 256 transceivers.

The reliability design of A, B, Z, Y pin is emphasized, including driver output over current protection and enhanced ESD design. The ESD protection level of A, B, Z, Y pin can be up to 15kV (Human Body Model).

## Contents

1 Home.....1	4 Characteristic Curve.....5
1.1 Feature and Package.....1	4.1 Typical Performance Curve.....5
1.2 Applications.....1	4.2 Parameter Measurement Information.....5
1.3 Functional Description.....1	5 Product working Description.....6
2 Pin Connection and Description.....2	6 Application Circuit.....7
3 IC Related Parameters.....3	7 Suggestions for Power Supply.....8
3.1 Absolute Maximum Rating.....3	8 Order Information.....8
3.2 Recommended Operating Conditions.....3	9 Package Information.....9
3.3 Electrical Characteristics.....4	10 Tape & Reel Information.....10
3.4 Transmission Characteristics.....5	
3.5 Physical Information.....5	

### Pin Connection

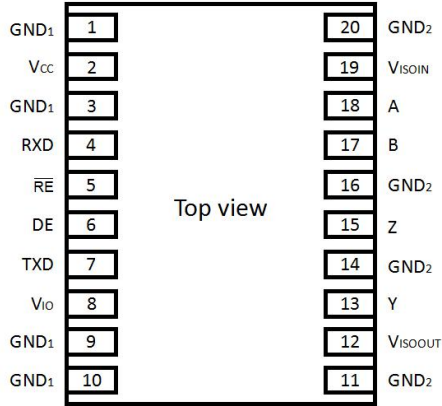

Note: All GND<sub>1</sub> pins are internally connected.  
All GND<sub>2</sub> pins are internally connected.

### Internal Block

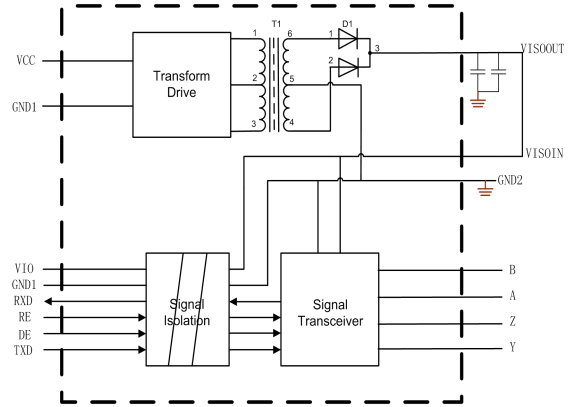

### Function Table

Letter	Description
H	High-Level
L	Low-Level
X	Unrelated
Z	High Impedance

Table 1. Driver Function table

TXD	DE	Output	
		Y	Z
H	H	H	L
L	H	L	H
X	L	Z	Z
OPEN	H	H	L

Table 2. Receiver Function table

Difference input $V_{ID} = (V_A - V_B)$	RE	RXD
$-0.01\text{ V} \leq V_{ID}$	L	H
$-0.2\text{ V} < V_{ID} < -0.01\text{ V}$	L	Uncertainty
$V_{ID} \leq -0.2\text{ V}$	L	L
X	H	H
Open circuit	L	H
Short circuit	L	H

## Pin Descriptions

Pin Number	Pin Name	Pin Functions
1	GND <sub>1</sub>	Ground (Logic side).
2	V <sub>CC</sub>	Power supply. By using 0.1uF ceramic capacitance ground(GND <sub>1</sub> ).
3	GND <sub>1</sub>	Ground (Logic side).
4	RXD	Receiver output pin.
5	$\overline{RE}$	Receiver enable input. When $\overline{RE}$ is low, if (A - B) ≥ -10 mV, then RXD = high. if (A - B) ≤ -200 mV, then RXD = low.
6	DE	Driver enable input. When DE is high, outputs are enabled. When DE is low, outputs are high impedance. Drive DE low and $\overline{RE}$ high to enter shutdown mode.
7	TXD	Driver input pin.
8	V <sub>IO</sub>	Power supply of Logic side. By using 1uF ceramic capacitance ground(GND <sub>1</sub> ).
9	GND <sub>1</sub>	Ground (Logic side).
10	GND <sub>1</sub>	Ground (Logic side).
11	GND <sub>2</sub>	Ground (Bus Side).
12	V <sub>ISOOUT</sub>	Insulation power output. By using 1uF Ceramic capacitance ground(GND <sub>2</sub> , pin11). The pin needs to be connected to pin19 in application.
13	Y	Driver Noninverting Output.
14	GND <sub>2</sub>	Ground (Bus Side).
15	Z	Driver inverting Output.
16	GND <sub>2</sub>	Ground (Bus Side).
17	B	Receiver Inverting Input.
18	A	Receiver Noninverting Input.
19	V <sub>ISOIN</sub>	Insulation power input. By using 0.1uF ceramic capacitance ground(GND <sub>2</sub> , pin20). The pin needs to be connected to pin12 in application.
20	GND <sub>2</sub>	Ground (Bus Side).

## Absolute Maximum Ratings

General test conditions: Free-air, normal operating temperature range (Unless otherwise specified).

Parameters	Unit
Supply voltage ( V <sub>CC</sub> )	-0.3V to +3.5V
V <sub>IO</sub> Input Voltag	-0.3V to+6V
Bus voltage	-8V to+13V
Digital Input Voltage (DE, $\overline{RE}$ , TXD, RXD)	-0.3V to+6V
Operating Temperature Range	-40°C to +105°C
Storage Temperature Range	-50°C to +125°C
Reflow Soldering Temperature	Peak temp. ≤250°C, maximum duration ≤60s at 217°C. Please also refer to IPC/JEDEC J-STD-020D. 3.

Important: Exposure to absolute maximum rated conditions for an extended period may severely affect the device reliability, and stress levels exceeding the "Absolute Maximum Ratings" may result in permanent damage.

## Recommended Operating Conditions

Symbol	Recommended Operating Conditions	Min.	Typ.	Max.	Unit
V <sub>CC</sub>	Supply voltage	3.15	3	3.45	V
V <sub>IO</sub>	Supply voltage	2.375	3.3	5.5	
V <sub>I</sub>	Voltage at any bus terminal (differential or common mode)	-7		12	
V <sub>IH</sub>	High-level input voltage(TXD, DE, ) $\overline{RE}$	2		V <sub>IO</sub>	
V <sub>IL</sub>	Low-level input voltage(TXD, DE, ) $\overline{RE}$	0		0.8	
I <sub>OS</sub>	Output current	Driver	-60	60	mA
		Receiver	-8	8	
R <sub>IN</sub>	Differential output load resistance	54	60		Ω
T <sub>A</sub>	Operating temperature range	-40		105	°C
-	Signaling rate			20	Mbps

## Electrical Characteristics

Symbol	Parameter	Conditions	Min.	Typ.	Max.	Unit	
<b>Driver</b>							
V <sub>OD</sub>	Differential driver output	No load	3.0			V	
		R <sub>L</sub> = 54Ω, Figure 7	1.5	2.0		V	
		R <sub>L</sub> = 100Ω, Figure 7	2.0			V	
ΔV <sub>OD</sub>	Δ V <sub>OD</sub>   for complementary output states	R <sub>L</sub> = 54Ω, Figure 7			±0.2	V	
V <sub>OC</sub>	Common-Mode output voltage	Figure 6	1		3	V	
ΔV <sub>OC(SS)</sub>	Δ V <sub>OC</sub>   for complementary output states	Figure 6	-0.1		0.1	V	
I <sub>OS</sub>	Output short-circuit current	-7V ≤ V <sub>OUT</sub> ≤ 12V		±110	±250	mA	
<b>Receiver</b>							
V <sub>IT(+)</sub>	Positive differential input threshold voltage	-7 V ≤ V <sub>CM</sub> ≤ +12 V			-10	mV	
V <sub>IT(-)</sub>	Negative differential input threshold voltage	-7 V ≤ V <sub>CM</sub> ≤ +12 V	-200			mV	
V <sub>hys</sub>	Hysteresis voltage (V <sub>IT+</sub> - V <sub>IT-</sub> )	-7 V ≤ V <sub>CM</sub> ≤ +12 V		20		mV	
R <sub>ID</sub>	Differential input resistance(A, B)	-7 V ≤ V <sub>CM</sub> ≤ +12 V	96			kΩ	
I <sub>I</sub>	Input current (A, B)	DE=0, RE=0, V <sub>CC</sub> =0 or 3.3V	V <sub>OUT</sub> = 12V		190	250	uA
			V <sub>OUT</sub> = -7V	-200	-110		uA
V <sub>OH</sub>	RXD output high voltage	I <sub>OUT</sub> = 20 μA, V <sub>A</sub> - V <sub>B</sub> = 0.2 V	V <sub>IO</sub> - 0.1			V	
		I <sub>OUT</sub> = 4 mA, V <sub>A</sub> - V <sub>B</sub> = 0.2 V	V <sub>IO</sub> - 0.4	V <sub>IO</sub> - 0.2		V	
V <sub>OL</sub>	RXD output low voltage	I <sub>OUT</sub> = -20 μA, V <sub>A</sub> - V <sub>B</sub> = -0.2 V			0.1	V	
		I <sub>OUT</sub> = -4 mA, V <sub>A</sub> - V <sub>B</sub> = -0.2 V			0.4	V	
<b>Power supply and safeguard characteristic</b>							
I <sub>CC</sub>	Supply current	DE = RE = 0V		18	40	mA	
I <sub>CC</sub>	Working current	Between Y, Z 100Ω load		95	125	mA	
		Between Y, Z 54Ω load		105	135	mA	
ESD	HBM	A, B, Y, Z to GND			±15	kV	
		Other pin			±2	kV	
	Contact	A, B, Y, Z to GND			±4	kV	
EFT	IEC61000-4-4	A, B, Y, Z and GND			±2	kV	
SURGE	IEC61000-4-5	A, B, Y, Z and GND(Common Mode)			±2	kV	
VI-O	Insulate voltage	TD341S485S-FT			3000	VDC	
		TDH341S485S-FT			5000	VDC	
	Insulate impedance		1			GΩ	
	Insulate capacitance			3		pF	
CMTI	Common mode transient immunity	TXD = V <sub>CC</sub> or 0 V, V <sub>CM</sub> = 1 kV, transient magnitude = 800 V	25			kV/us	

## Transmission Characteristics

Symbol	Parameter	Conditions	Min.	Typ.	Max.	Unit
-	Maximum data rate	Duty 40% ~ 60%			20	Mbps
T <sub>PHL</sub> , T <sub>PLH</sub>	Driver propagation delay	R <sub>L</sub> = 54Ω, C <sub>L</sub> = 50pF, Figure 8		25	90	ns
T <sub>PHL</sub> -T <sub>PLH</sub>	Driver skew (  T <sub>PHL</sub> - T <sub>PLH</sub>   )				15	ns
T <sub>R</sub> , T <sub>F</sub>	Driver rise/fall time				60	ns
T <sub>PHL</sub> , T <sub>PLH</sub>	Receiver propagation delay	C <sub>L</sub> = 15pF Figure 9		60	150	ns
T <sub>PHL</sub> -T <sub>PLH</sub>	Receiver skew (  T <sub>PLH</sub> - T <sub>PHL</sub>   )			10	20	ns
T <sub>R</sub> , T <sub>F</sub>	Receiver rise/fall time				25	ns

# Physical Specifications

Parameters	Value	Unit
Weight	1.0(Typ. )	g

## Typical Performance Curves

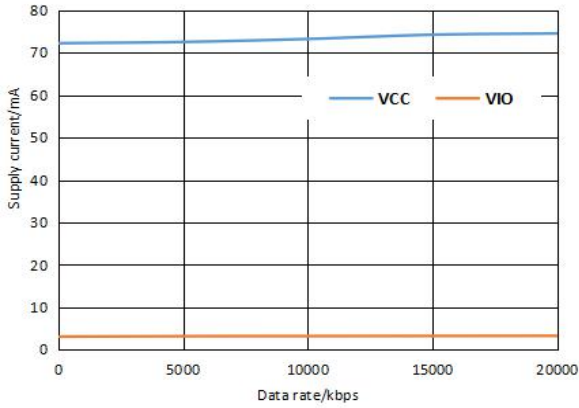

Figure 1. Supply current vs. Data rate

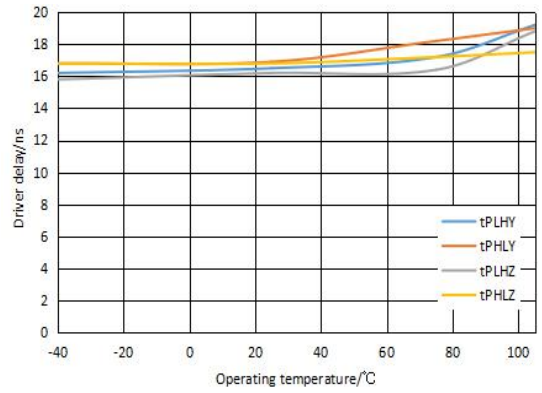

Figure 2. Driver delay vs. Operating temperature

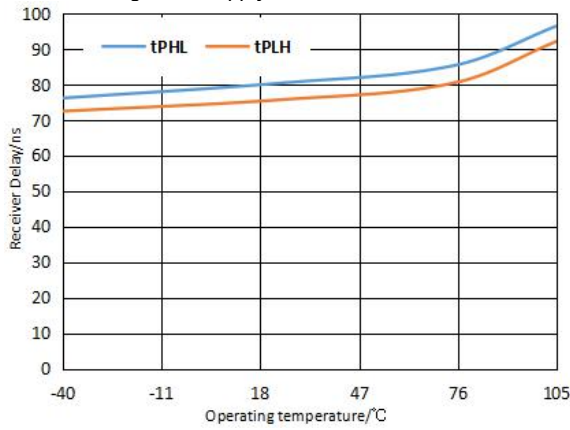

Figure 3. Receiver delay vs. Operating temperature

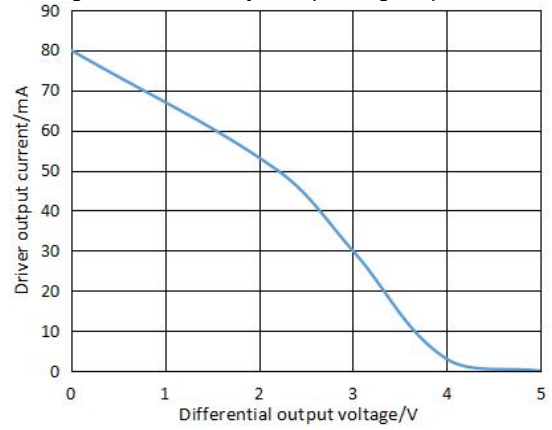

Figure 4. Driver output current vs. Differential output voltage

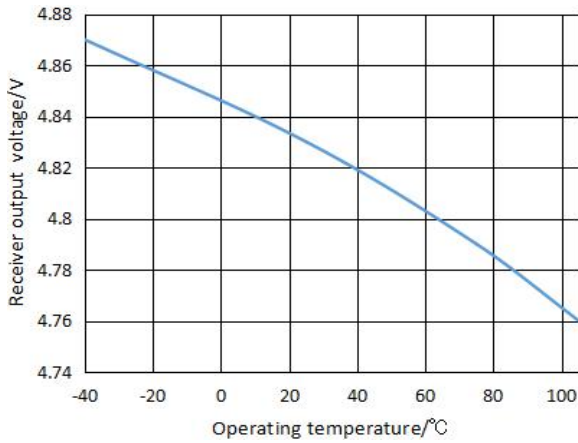

Figure 5. Receiver output high voltage vs. Operating temperature

## Test Circuits

Note: Testing the condition burden capacitance including test to stretch forward and testing fixture parasitic capacitance. Testing semaphore upswing and drop to follow < 6nS, frequency = 100kHz, duty = 50%. resistance ZO = 54Ω.

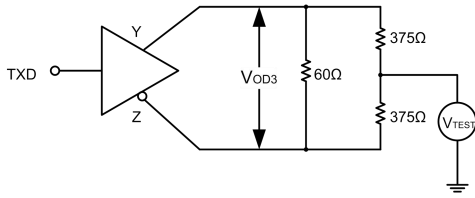

Figure 6. Driver test circuit, VOD with common-mode loading

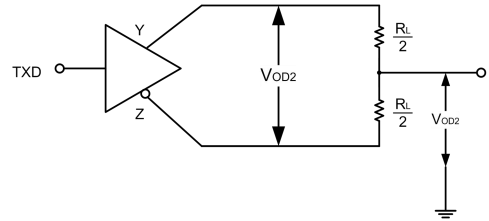

Figure 7. Driver test circuit

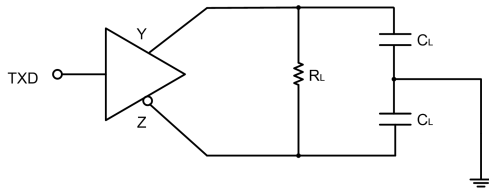

Figure 8. Drive propagation delay test circuit and wave forms

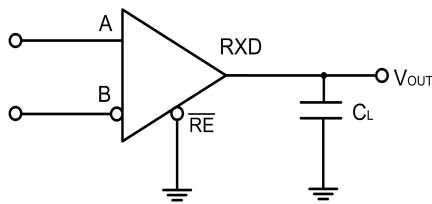
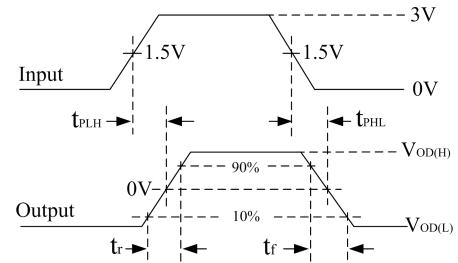
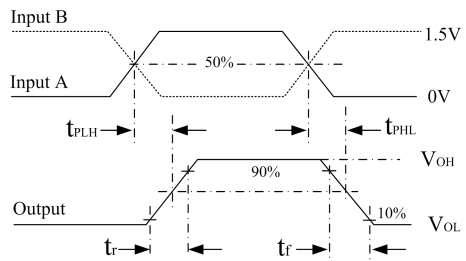

Figure 9. Receiver propagation delay test circuit and wave forms



## Detailed Description

TD(H)341S485S-FT is a full-duplex enhanced RS485 isolated transceiver with isolated power supply. In addition to an isolated power supply, each transceiver contains a drive and a receiver. The transceiver has a standby bus failure protection function to ensure that the receiver output is high when the receiver input is open, short, or when the bus is idle. TD(H)341S485S-FT adopts 3.3VDC power supply. The whole machine can monitor the overall working state of the module and limit the output high current, so as to prevent the bus overload or short circuit from causing non-recoverable damage to the transceiver.

Receiver input filter: TD(H)341S485S-FT receiver integrated high performance input filter, the filter can greatly enhance the receiver's noise suppression ability to high speed differential signal. Therefore, the transmission delay of the receiver is also caused by this reason.

Bus failure protection: In general, when  $-200\text{mV} < A - B < -10\text{mV}$ , the bus receiver will be in an uncertainty state. This phenomenon occurs when the bus is idle. Bus failure protection ensures that the receiver outputs a high level when the receiver input is open, short, or when the bus access port matches the resistance. TD(H)341S485S-FT receiver threshold voltage is relatively accurate, and the threshold voltage to the reference ground has a margin of at least 10mV, which can ensure that even if the bus differential voltage is 0V, the receiver output level is high, and meets the requirements of EIA/TIA-485 standard  $\pm 200\text{mV}$ .

The bus load capacity (256 point): standard RS485 receiver input impedance is defined as 12 kΩ (unit load). A standard RS485 driver can drive at least 32 load units. TD(H)341S485S-FT bus receiver designed by 1/8 unit load, the input impedance is greater than 96 kΩ. As a result, the bus allows access to more transceivers (up to 256). TD(H)341S485S-FT can also be mixed with the standard RS485 transceiver with 32 unit loads (cumulative receiver load cannot exceed 32 units).

Low power SHUTDOWN mode: When high level is input and low power is input, the transceiver enters SHUTDOWN mode. When the transceiver enters off mode, its overall standby power consumption decreases, DE can be short-connected and controlled by the same I/O. If the high level is input and the holding time of DE low level is less than 50ns, the transceiver cannot enter the off mode. If the holding time can be maintained at least 600ns, the transceiver will reliably enter the off mode.

Drive output protection: TD(H)341S485S-FT internal integrated drive short circuit (or overcurrent) protection module. In case of bus error or driver short circuit, the module can limit the output current of the driver within a certain limit.



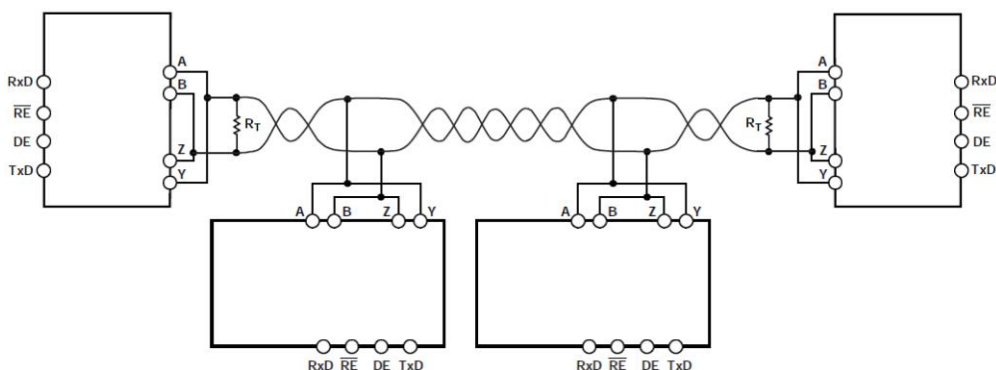

Figure10. The typical model applies telephone ( half-duplex )

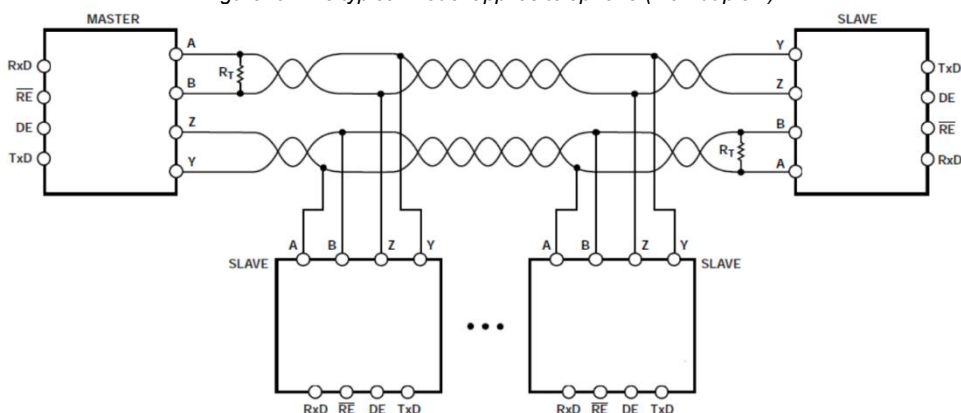

Figure11. The typical model applies telephone ( full-duplex )

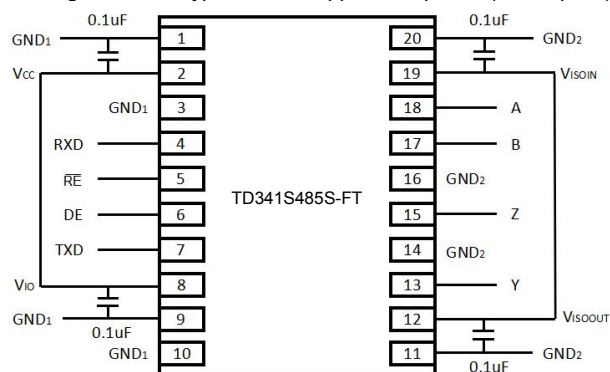

Figure12. Type PCB layout

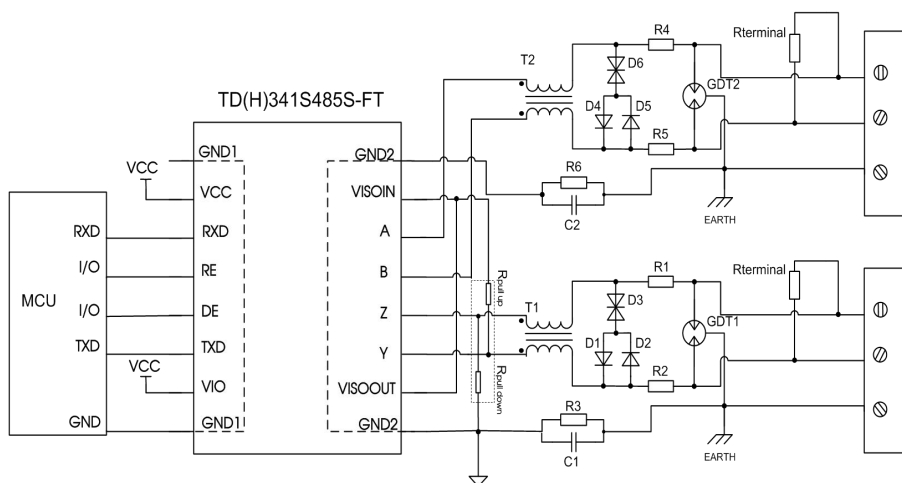

Figure13. Port protection circuit for harsh environments

Recommended components and values:

Component	Recommended part, value	Component	Recommended part, value
R3,R6	1M $\Omega$	R1,R2,R4,R5	2.7 $\Omega$ /2W
C1,C3	1nF, 2kV	D1,D2,D4,D5	1N4007
T1,T2	ACM2520-301-2P	D3,D6	SMBJ8.5CA
GDT1,GDT2	B3D090L	R <sub>terminal</sub>	120 $\Omega$

As the modules internal A / B / Z / Y lines come with its own ESD protection, which generally satisfy most application environments without the need for additional ESD protection devices. For harsh and noisy application environments such as motors, high voltage/current switches, lightning and similar however, we recommended that the user protects the module's A / B / Z / Y lines with additional measures and external components such as TVS tube, common mode inductors, Gas discharge tube, shielded twisted pair of wires with the same single network Earth point. Figure 13 shows our recommended circuit diagram for such type of applications with components and values given in the table above. This recommendation is for reference only and may have to be adapted accordingly with appropriate component values in order to match the actual situation and application.

Note: Select the R<sub>terminal</sub> according to the actual application.

## Recommendations

- ① Power isolation V<sub>ISOOUT</sub> need through a series of capacitors connected to the output pin V<sub>ISOIN</sub>, in addition to the mentioned in article 5 of the pull up and down function, the power supply is not recommended for other purposes, otherwise it may cause the bus voltage did not meet the requirements of communication, causes the communication failure.
- ② V<sub>IO</sub> pin decide the output level of RXD pin. Normally, V<sub>IO</sub> pin need to connected to the V<sub>CC</sub> pin to support 3.3V microprocessors. V<sub>IO</sub> pin need to disconnect to the V<sub>CC</sub> pin and need a 5V power supply separately to support 5V microprocessors if necessary.
- ③ DE and TXD contains a 10k $\Omega$  pull up resistor each, RE contains a 10k $\Omega$  pull down resistor.
- ④ DE, RE, TXD pin is always not allow to set to open drain output state connect the controller, otherwise it will lead to uncertain consequences.
- ⑤ To maintain bus idle stability, we need at least one node will pull up Y to V<sub>ISOIN</sub> and drop down Z to GND<sub>2</sub> on the bus. Overall network at the same time pull up and drop down resistors of the parallel value must around 380 $\Omega$  to 420 $\Omega$ (0.2W)

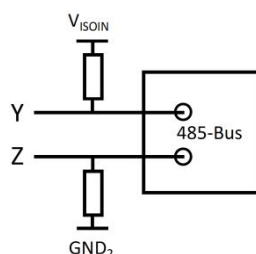

Figure14. Pull up and drop down resistance connect

- ⑥ Hot-swap is not supported.
- ⑦ If the external input of TXD is insufficient, the pull-up resistor should be added according to the situation.
- ⑧ Refer to IPC 7093 for the welding process design of this product. For detailed operation guidance, please refer to *Hot Air Gun Welding Operation Instruction for DFN Package Product* or *Welding Operation Instruction for DFN Package Product*.

## Ordering Information

Part number	Package	Number of pins	Product marking	Tape & Reel
TD341S485S-FT	DFN	20	TD341S485S-FT	300/REEL
TDH341S485S-FT	DFN	20	TDH341S485S-FT	300/REEL



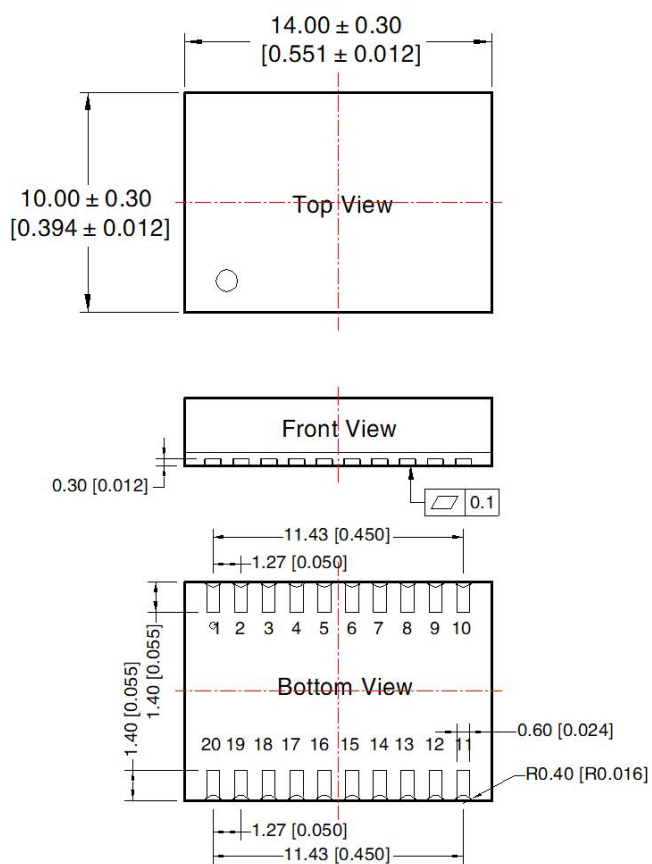

Note:  
 Unit: mm[inch]  
 Pin diameter tolerances :  $\pm 0.10$  [± 0.004]

THIRD ANGLE PROJECTION

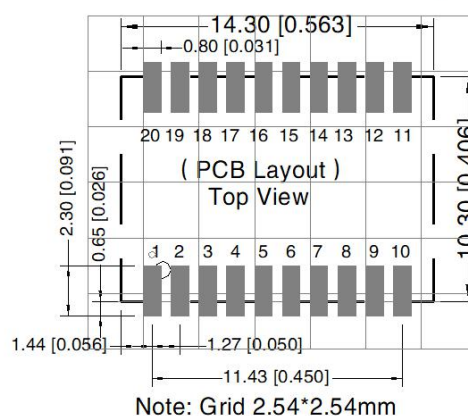

Pin-Out			
Pin	Mark	Pin	Mark
1	GND <sub>1</sub>	11	GND <sub>2</sub>
2	V <sub>CC</sub>	12	V <sub>ISOOUT</sub>
3	GND <sub>1</sub>	13	Y
4	RXD	14	GND <sub>2</sub>
5	$\overline{RE}$	15	Z
6	DE	16	GND <sub>2</sub>
7	TXD	17	B
8	V <sub>IO</sub>	18	A
9	GND <sub>1</sub>	19	V <sub>ISOIN</sub>
10	GND <sub>1</sub>	20	GND <sub>2</sub>

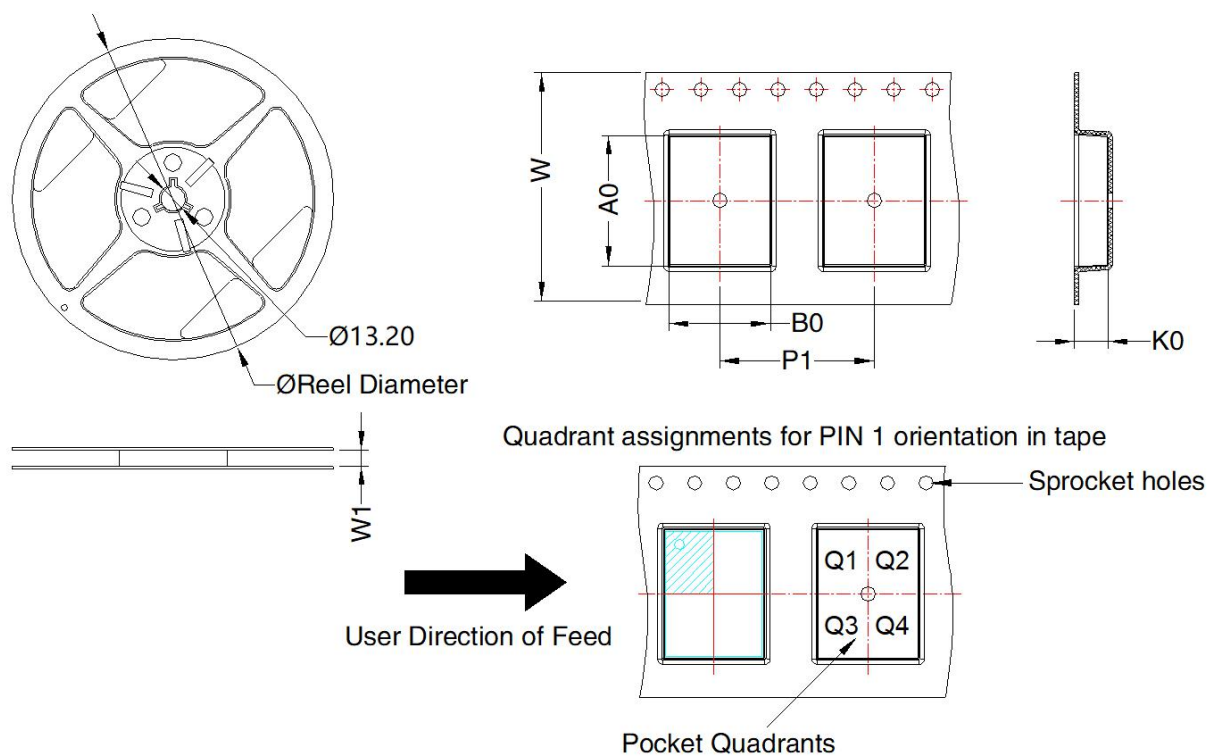

Device	Package Type	Pin	MPQ	Reel Diameter (mm)	Reel Width W1 (mm)	A0 (mm)	B0 (mm)	K0 (mm)	P1 (mm)	W (mm)	Pin1 Quadrant
TD(H)341S485S-FT	DFN 10x14	20	300	180.0	24.4	14.52	10.52	3.5	16.0	24.0	Q1

## MORNSUN Guangzhou Science & Technology Co., Ltd.

Address: No. 5, Kehui St. 1, Kehui Development Center, Science Ave., Guangzhou Science City, Huangpu District, Guangzhou, P. R. China  
 Tel: 86-20-38601850 Fax: 86-20-38601272 E-mail: [info@mornsun.cn](mailto:info@mornsun.cn) [www.mornsun-power.com](http://www.mornsun-power.com)