

## TD(H)341S232H DFN package isolated RS232 Transceiver

### Features

- Ultra-small, ultra-thin, chip scale DFN package
- Compliant with TIA/EIA-232 standard
- Integrated isolated 3.3V power
- I/O power supply range supports 3.3V microprocessors
- High isolation to 5000VDC (TD341S232H 3000VDC)
- Bus-Pin ESD protection up to 15kV(HBM)
- Baud rate up to 120kbps
- >25kV/us CMTI
- Industrial operating ambient temperature range: -40°C to +85°C
- Meet AEC-Q100 standards
- EN62368 approval
- Moisture Sensitivity Level (MSL) 3

### Applications

- Industrial Automation
- Building Automation
- Smart Electricity Meter

### Functional Description

TD(H)341S232H is a RS232 transceiver with low power consumption and high electrostatic protection and ESD protection, and it is fully compliant with TIA/EIA-232 standards. The main function of the product will be to convert the TTL level to the level of the RS232 protocol to achieve signal isolation. And the product comes with a constant voltage isolation power supply, which can achieve 3000/5000VDC electrical isolation, and can also be easily embedded in user equipment, so that the equipment can easily realize the connection function of the RS232 protocol network.

TD(H)341S232H focuses on strengthening the reliability design of T<sub>OUT</sub> and R<sub>IN</sub> pins and enhanced ESD design on the basis of traditional IC. Its T<sub>OUT</sub> and R<sub>IN</sub> port ESD tolerance is as high as 15kV (Human Body Model).

### Package

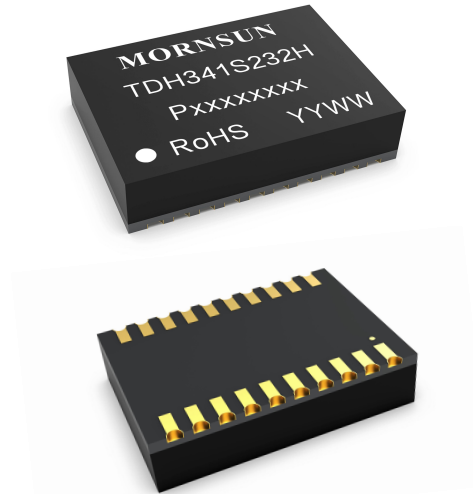

# Contents

1	Home.....	1	4	Characteristic Curve.....	5
1.1	Feature and Package.....	1	4.1	Typical Performance Curve.....	5
1.2	Applications.....	1	5	Application Circuit.....	6
1.3	Functional Description.....	1	6	Suggestions for Power Supply.....	7
2	Pin Connection and Description.....	2	7	Order Information.....	7
3	IC Related Parameters.....	3	8	Package Information.....	8
3.1	Absolute Maximum Rating.....	3	9	Tape & Reel Information.....	9
3.2	Recommended Operating Conditions.....	3			
3.3	Electrical Characteristics.....	4			
3.4	Transmission Characteristics.....	5			
3.5	Physical Information.....	5			

## Pin Connection

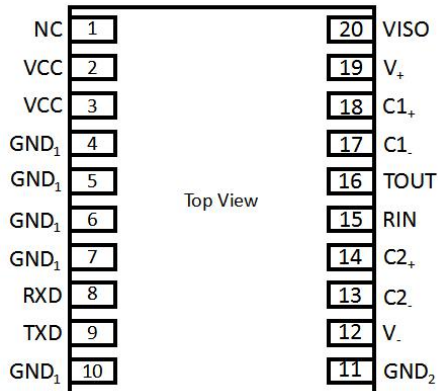

Note: All GND<sub>1</sub> pins are internally connected.

## Internal Block

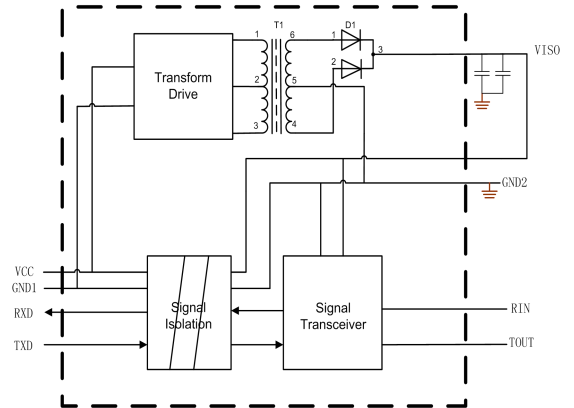

## Function Table

Letter	Description
H	High-Level
L	Low-Level

Table 1. Driver Function table

Transceiver function	Input	Output
Send function	TXD	T_OUT
	L	H
	H	L

Table 2. Receiver Function table

Transceiver function	Input	Output
Receive function①	R_IN	RXD
	≥2.4V	L
	≤0.6V	H
	0.6V≤RXD≤2.4V	Uncertainty

Note : ①The receiving threshold varies slightly with Vcc.

## Pin Descriptions

Pin Number	Pin Name	Pin Functions
1	NC	No function pin, can be left floating.
2	V <sub>CC</sub>	Power supply. By using 1uF ceramic capacitance ground(GND <sub>1</sub> ).
3	V <sub>CC</sub>	Power supply. By using 1uF ceramic capacitance ground(GND <sub>1</sub> ).
4	GND <sub>1</sub>	Logic side reference ground.
5	GND <sub>1</sub>	Logic side reference ground.
6	GND <sub>1</sub>	Logic side reference ground.
7	GND <sub>1</sub>	Logic side reference ground.
8	RXD	Receiver signal output pin.
9	TXD	Driver input pin.
10	GND <sub>1</sub>	Logic side reference ground.
11	GND <sub>2</sub>	Isolated output reference ground.
12	V <sub>-</sub>	Negative power generated internally,this pin is recommended to be connected to the isolated output reference ground(GND <sub>2</sub> ) through a 0.1uF capacitor.
13,14	C2-,C2+	The positive and negative connections of the charge pump capacitor. These two pins are connected to an external capacitor C2, 0.1uF capacitor is recommended.
15	R <sub>IN</sub>	Receiver input. This input accepts RS-232 signal level.
16	T <sub>OUT</sub>	Drive output. This pin outputs the RS-232 signal level.
17,18	C1-,C1+	The positive and negative connections of the charge pump capacitor. These two pins are connected to an external capacitor C1, and a 0.1uF capacitor is recommended.
19	V <sub>+</sub>	Positive power generated internally,this pin is recommended to be connected to the isolated output reference ground(GND <sub>2</sub> ) through a 0.1uF capacitor.
20	V <sub>ISO</sub>	Isolated power output terminal, this pin must be connected to the isolated output reference ground(GND <sub>2</sub> ) through a 1uF capacitor.

## Absolute Maximum Ratings

General test conditions: Free-air, normal operating temperature range (Unless otherwise specified).

Parameters	Unit
Supply voltage	-0.3V to +3.5V
Driver input pin, TXD	-0.3V to +3.5V
Driver output pin, T <sub>OUT</sub>	-13.2V to +13.2V
Receiver input pin, R <sub>IN</sub>	-25V to +25V
Receiver output pin, RXD	-0.3V to +3.5V
Operating Temperature Range	-40°C to +105°C
Storage Temperature Range	-50°C to +150°C
Reflow Soldering Temperature	Peak temp. ≤250°C, maximum duration ≤60s at 217°C. Please also refer to IPC/JEDEC J-STD-020D. 3.

Important: Exposure to absolute maximum rated conditions for an extended period may severely affect the device reliability, and stress levels exceeding the "Absolute Maximum Ratings" may result in permanent damage. All voltage values are based on the reference ground(GND).

## Recommended Operating Conditions

Symbol	Recommend an operate condition	Min.	Typ.	Max.	Unit
V <sub>CC</sub>	Supply voltage	3.15	3.3	3.45	V
V <sub>IH</sub>	High-level input voltage(TXD)	2		V <sub>CC</sub>	
V <sub>IL</sub>	Low-level input voltage(TXD)	0		0.8	
I <sub>OS</sub>	Output current	Driver	2		mA
		Receiver			
R <sub>L</sub>	Output load resistance		3k		Ω
T <sub>A</sub>	Operating temperature range	-40		85	°C
-	Signaling rate			120	kbps

## Electrical Characteristics

Symbol	Parameter	Conditions	Min.	Typ.	Max.	Unit
<b>Driver</b>						
V <sub>TOUT</sub>	Drive output high level	R <sub>L</sub> =3kΩ to GND <sub>2</sub>	5	7		V
	Drive output low level	R <sub>L</sub> =3kΩ to GND <sub>2</sub>		-7	-5	V
R <sub>TOUT</sub>	Driver output impedance		300			Ω
I <sub>sc</sub>	Driver short circuit current				60	mA
<b>Receiver</b>						
V <sub>RIN</sub>	Receiver input range		-25		25	V
V <sub>RIL</sub>	Receiver input low threshold voltage		0.6	0.9		V
V <sub>RIH</sub>	Receiver input high threshold voltage			1.5	2.4	V
	Receiver input hysteresis			0.4		V
R <sub>RIN</sub>	Receiver input impedance		3	5	7	kΩ
V <sub>ROH</sub>	RXD high level output voltage		V <sub>cc</sub> - 0.4	V <sub>cc</sub> - 0.1		V
V <sub>ROL</sub>	RXD low level output voltage				0.4	V
<b>Power supply and safeguard characteristic</b>						
I <sub>cc</sub>	Supply current			25	35	mA
I <sub>cc</sub>	Working current	No load		30	45	mA
		R <sub>L</sub> =3kΩ to GND <sub>2</sub>		30	45	mA
ESD	HBM	T <sub>OUT</sub> , R <sub>IN</sub> to GND <sub>2</sub>			±15	kV
		Other pin			±2	kV
	Contact	T <sub>OUT</sub> , R <sub>IN</sub> to GND <sub>2</sub>			±8	kV
EFT	IEC61000-4-4	T <sub>OUT</sub> , R <sub>IN</sub> to GND <sub>2</sub>			±2	kV
SURGE	IEC61000-4-5	T <sub>OUT</sub> , R <sub>IN</sub> to GND <sub>2</sub>			±2	kV
VI-O	Insulate voltage	TD341S232H			3000	VDC
		TDH341S232H			5000	VDC
	Insulate impedance		1			GΩ
	Insulate capacitance			50		pF
CMTI	Common mode transient immunity	TXD = V <sub>cc</sub> or 0 V, V <sub>CM</sub> = 1 kV, transient magnitude = 800 V	25			kV/us

Note : ESD indicators are non-charged test specifications, GND2 need to be connected to the earth during testing.

## Transmission Characteristics

Symbol	Parameter	Conditions	Min.	Typ.	Max.	Unit
-	Maximum data rate	Duty 40% ~ 60%			120	kbps
T <sub>PHL</sub> , T <sub>PLH</sub>	Driver propagation delay	R <sub>L</sub> = 3kΩ to 7kΩ , C <sub>L</sub> = 50pF			2	us
T <sub>PHL</sub> , T <sub>PLH</sub>	Receiver propagation delay	C <sub>L</sub> = 15pF			2	us

## Physical Specifications

Parameters	Value	Unit
Weight	1.0(Typ. )	g

## Typical Performance Curves

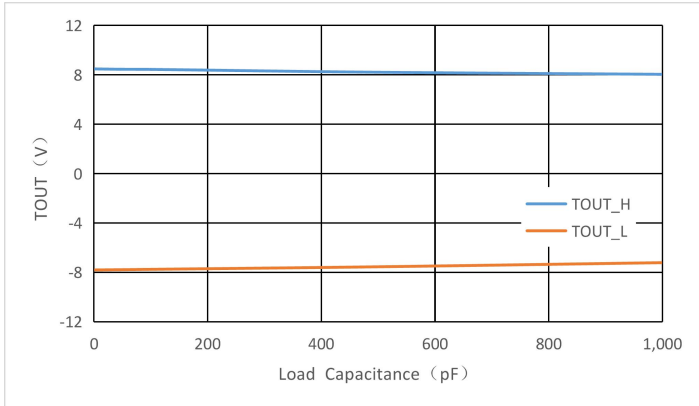

Figure 1. Transmitter Output Voltage High/Low VS Load Capacitance at 120 kbps

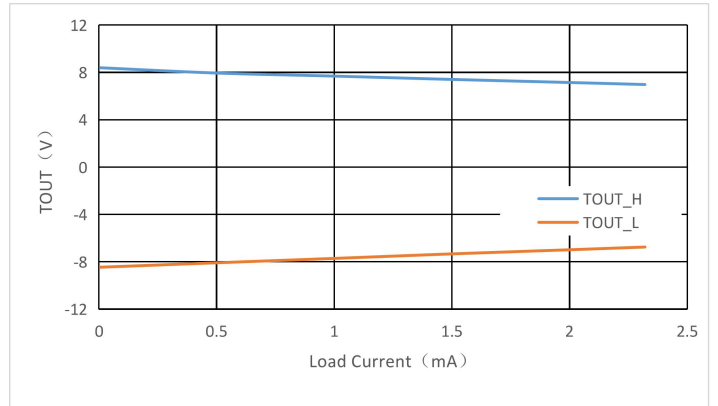

Figure 2. Transmitter Output Voltage High/Low VS Load Current

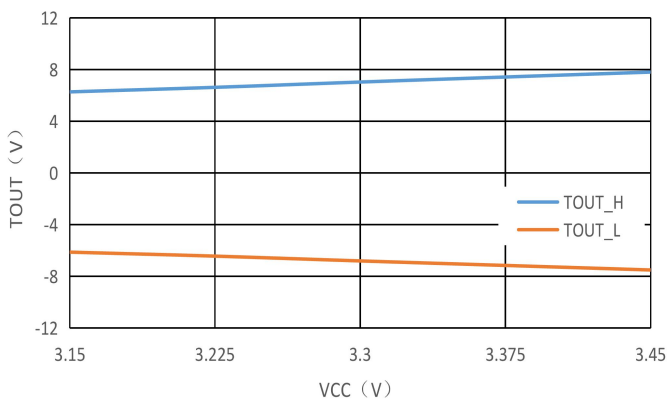

Figure 3. Transmitter Output Voltage High/Low VS V<sub>CC</sub>, R<sub>L</sub>=3 kΩ

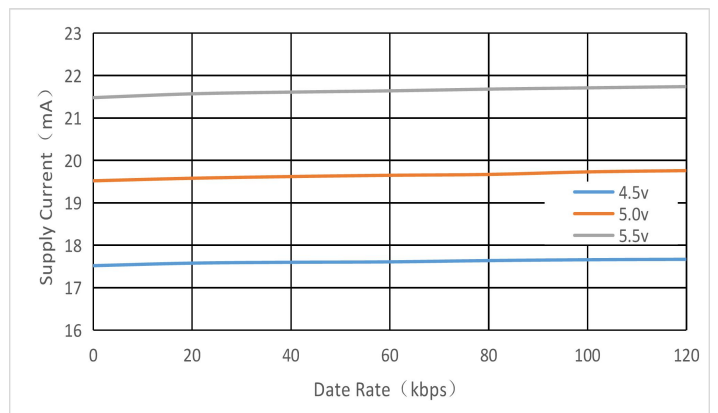

Figure 4. Supply current VS Data rate

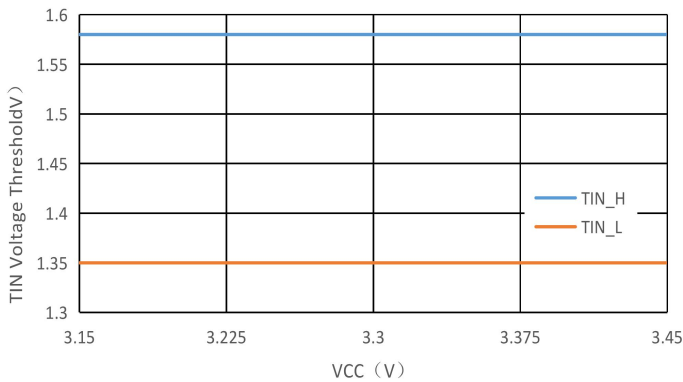

Figure 5. TIN Voltage Threshold VS V<sub>CC</sub>

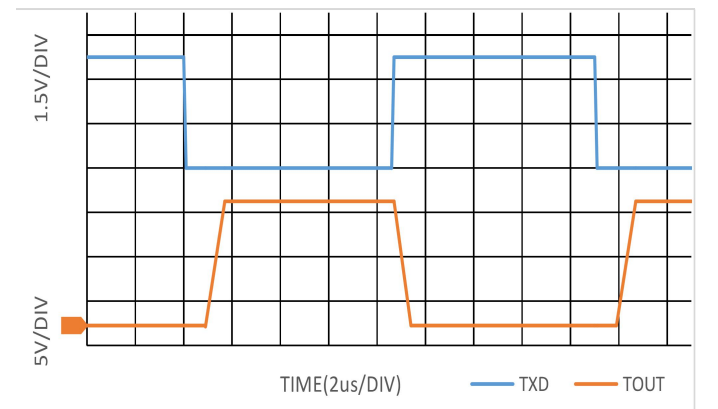

Figure 6. 120kbps Data Transmission (V<sub>CC</sub>=3.3V, R<sub>L</sub>=3 kΩ)

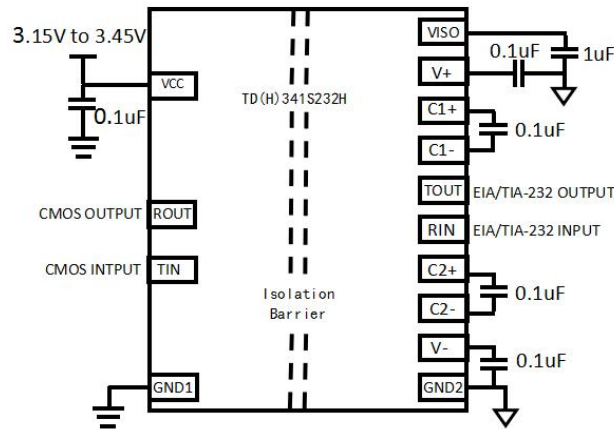

Figure7. The typical model applies telephone

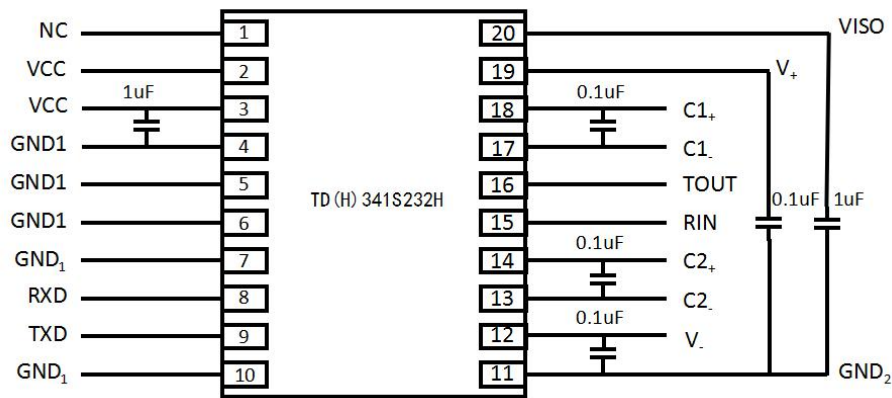

Figure8. Type PCB layout

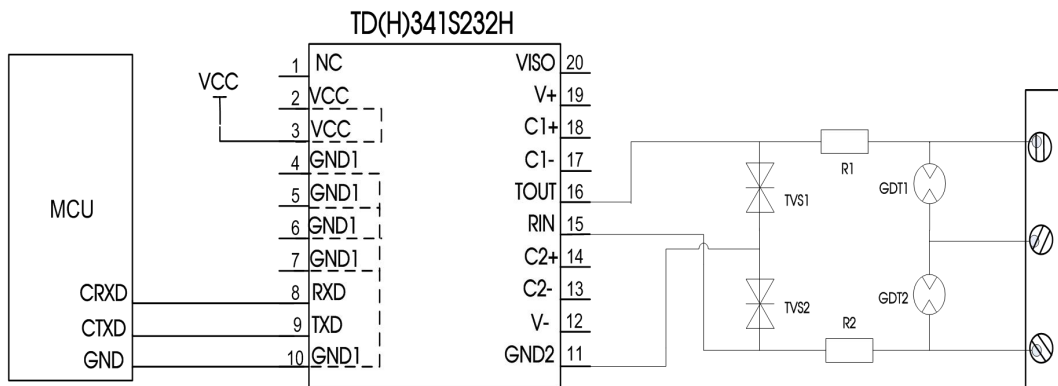

Figure9. Port protection circuit for harsh environments

Recommended components and values:

Components	TD341S232H	TDH341S232H
TVS1, TVS2	SMCJ15CA	
R1, R2	12Ω/2W(Wire-wound resistor)	
GDT1, GDT2	S30-A90X	

When the module is used in applications with harsh environment, it can be susceptible to large energy like lightning strike, etc. in which case, it is essential to add an adequate protection circuit to the 232 signal ports to protect the system from failure and maintain a reliable bus communication. Figure 9 provides a recommended protection circuit design for high-energy lightning surges, with a degree of protection related to the selected protection

device. Parameter description lists a set of recommended circuit parameters, which can be adjusted according to the actual application situation. Also, when using the shielded cable, the reliable single-point grounding of the shield must be achieved.

Note: The recommended components and values is a general guideline only and must be verified for the actual user's application.

## Recommendations

- ①The power supply is not recommended for other purposes, otherwise it may cause the bus voltage did not meet the requirements of communication, causes the communication failure.
- ②Hot-swap is not supported.
- ③If the external input of TXD is insufficient, the pull-up resistor should be added according to the situation.
- ④Refer to *IPC 7093* for the welding process design of this product. For detailed operation guidance, please refer to *Hot Air Gun Welding Operation Instruction for DFN Package Product* or *Welding Operation Instruction for DFN Package Product*.

## Ordering Information

Part number	Package	Number of pins	Product marking	Tape & Reel
TD341S232H	DFN	20	TD341S232H	300/REEL
TDH341S232H	DFN	20	TDH341S232H	300/REEL

THIRD ANGLE PROJECTION 

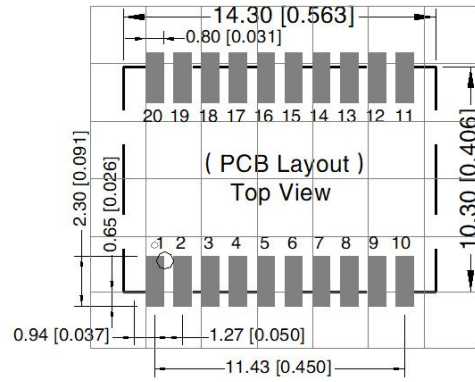
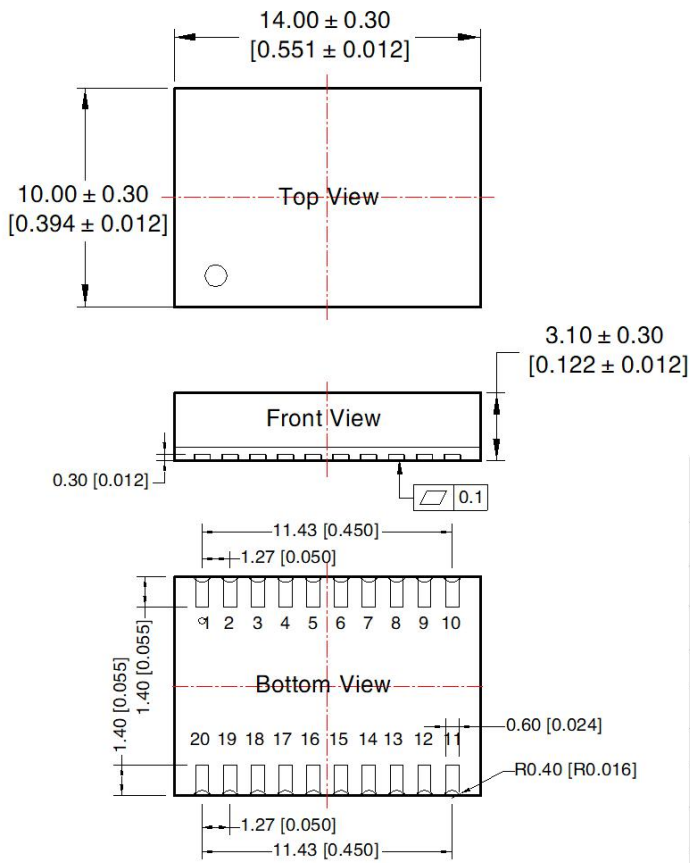

Note: Grid 2.54\*2.54mm

Pin-Out			
Pin	Mark	Pin	Mark
1	NC	11	GND <sub>2</sub>
2	V <sub>CC</sub>	12	V-
3	V <sub>CC</sub>	13	C2-
4	GND <sub>1</sub>	14	C2+
5	GND <sub>1</sub>	15	R <sub>IN</sub>
6	GND <sub>1</sub>	16	T <sub>OUT</sub>
7	GND <sub>1</sub>	17	C1-
8	RXD	18	C1+
9	TXD	19	V+
10	GND <sub>1</sub>	20	V <sub>ISO</sub>

Note:  
 Unit: mm[inch]  
 General tolerances:  $\pm 0.10$  [± 0.004]



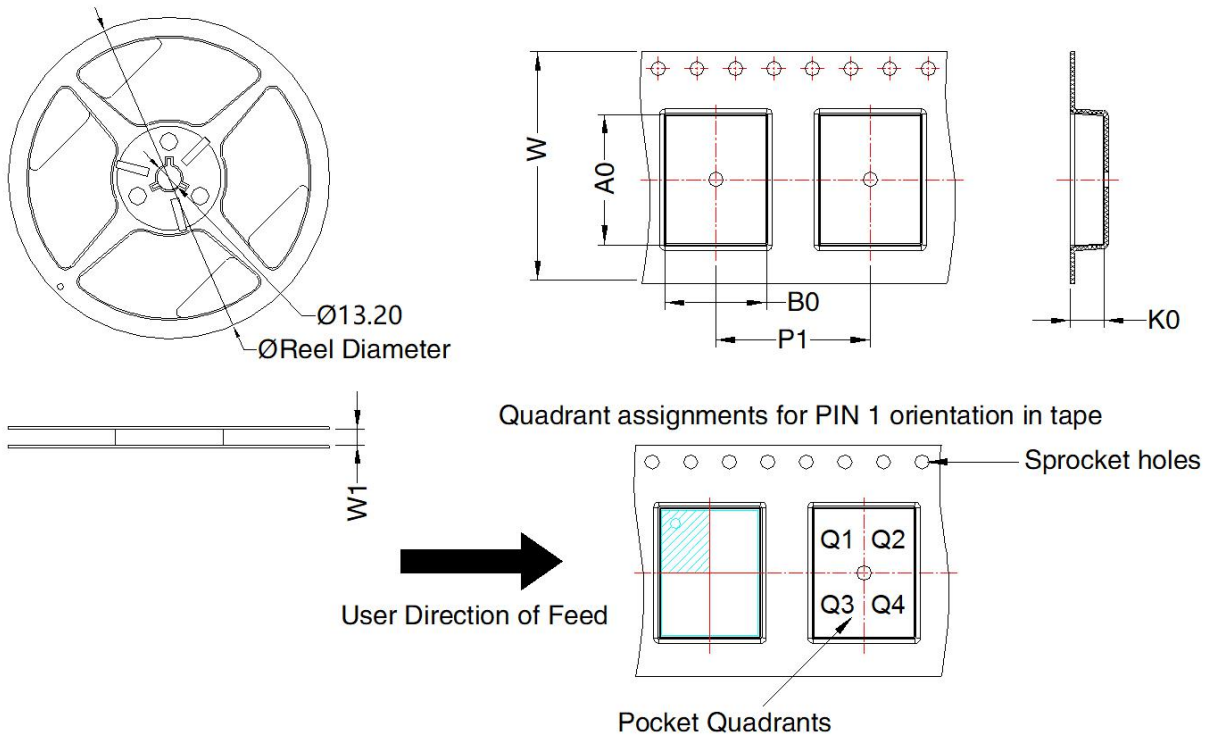

Device	Package Type	Pin	MPQ	Reel Diameter (mm)	Reel Width W1 (mm)	A0 (mm)	B0 (mm)	K0 (mm)	P1 (mm)	W (mm)	Pin1 Quadrant
TD(H)341S232H	DFN 10x14	20	300	180.0	24.4	14.52	10.52	3.5	16.0	24.0	Q1

## MORNSUN Guangzhou Science & Technology Co., Ltd.

Address: No. 5, Kehui St. 1, Kehui Development Center, Science Ave., Guangzhou Science City, Huangpu District, Guangzhou, P. R. China  
 Tel: 86-20-38601850 Fax: 86-20-38601272 E-mail: [info@mornsun.cn](mailto:info@mornsun.cn) [www.mornsun-power.com](http://www.mornsun-power.com)