

150W, AC-DC Brick Converter



FEATURES

- Ultra-wide 85 - 305VAC and 120 - 430VDC input voltage range
- Typical efficiency up to 92%, power factor up to 0.99
- International standard half brick package
- Compact size, high power density
- Over temperature protection, input reverse polarity protection, over-voltage/over-current/output short circuit protection
- Designed to meet UL/EN/IEC62368 standards

LBH150-13Bxx series is a new generation product of Mornsun's ultra compact size and highly efficient green power converter. It is a standard half brick package size with ultra-wide input voltage, high efficiency, high reliability and reinforced isolation. The products are safe and reliable with good EMC performance, the safety specifications meet the international UL/EN/IEC62368 standards. They are widely used in switching equipment, access equipment, mobile communications, microwave communications, optical transmission, routers and other areas of the communication, as well as electronics and mechanical equipment etc. For harsh EMC environment, the application circuit in the datasheet is strongly recommended.

Selection Guide

Part No.	Output Power (W)	Nominal Output Voltage and Current(Vo/Io)	Efficiency at 230VAC (%) Typ.	Capacitive Load (uF) Max.
LBH150-13B12	150	12V/12.5A	92	4000
LBH150-13B24		24V/6.25A	92	1500
LBH150-13B28		28V/5.36A	92	1500
LBH150-13B48		48V/3.13A	92	470
LBH150-13B54		54V/2.78A	92	470

Input Specifications

Item	Operating Conditions	Min.	Typ.	Max.	Unit
Input Voltage Range	AC input	85	--	305	VAC
	DC input	120	--	430	VDC
Input Frequency		47	--	63	Hz
Power Factor*	50/60Hz, 115VAC/230VAC, Pout=150W	0.96	0.99	--	--
Input Current	115VAC	--	--	2	A
	230VAC	--	--	1	
Inrush Current	230VAC, Ta=25°C	--	--	30	
THD*	Ta=25°C, Vin=115/230V, Pout=150W	--	5	--	%
Input Under-voltage Protection	Under-voltage protection start (Input voltage drops from high to low)	70	--	80	VAC
	Under-voltage protection start (Input voltage rises from low to high)	75	--	85	
Recommended External Input Fuse		30.5A/300V, slow-blow, required			
Hot Plug		Unavailable			
Grounded Mode	PE is required for aluminum substrate application				

Note: *The power factor and THD test result are based on recommended circuit.

Output Specifications

Item	Operating Conditions	Min.	Typ.	Max.	Unit
Output Voltage Accuracy		--	±2	--	%
Line Regulation	Full load	--	±0.5	--	
Load Regulation		--	±0.1	--	

Ripple & Noise*	20MHz bandwidth (peak-to-peak value) Load at room temperature >20%	12V	--	100	150	mV
		24V	--	200	250	
		28V	--	200	300	
		48V	--	300	400	
		54V	--	300	400	
Temperature Coefficient			--	±0.02	--	%/°C
Stand-by Power Consumption			--	2	4	W
Minimum Load			0	--	--	%
Hold-up Time			--	8	--	ms
Short Circuit Protection			Hiccup, continuous, self-recovery			
Over-current Protection			120% Io, self-recover after fault disappear			
Over-voltage Protection	12VDC output		≤16VDC (Hiccup)			
	24VDC output		≤32VDC (Hiccup)			
	28VDC output		≤35VDC (Hiccup)			
	48VDC output		≤60VDC (Hiccup)			
	54VDC output		≤63VDC (Hiccup)			
No-load Output Of Auxiliary Source	Maximum pulling current about 10mA, take HU- as for reference ground (Internal resistor in series 1 k Ω)	8	12	15		V
Over Temperature Protection	Over-temperature protection start (Aluminum substrate temperature) until power off	105	--	115		°C
	Over-temperature protection recovery	Reset input				
ENA Remote Control ON/OFF	Enable control pin	ENA connect to HU- , output is normal				
		ENA disconnect to HU- , output turn off				

Note: *The "parallel cable" method is used for ripple and noise test, please refer to AC-DC Converter Application Notes for specific information.

General Specifications

Item	Operating Conditions	Min.	Typ.	Max.	Unit
Isolation	Input - Output	3000	--	--	VAC
	Input - PE	1500	--	--	
	Output - PE	1500	--	--	
Insulation Resistance	Input - Output	100	--	--	M Ω
	Input - PE	100	--	--	
	Output - PE	100	--	--	
Operating Temperature	Al-Substrate temperature	-40	--	+100	°C
Storage Temperature		-40	--	+100	
Storage Humidity		--	--	95	%RH
Soldering Temperature	Wave-soldering	260 ± 5°C; time: 5 - 10s			
	Manual-welding	360 ± 10°C; time: 3 - 5s			
Power Derating	+90°C to +100°C (Al-Substrate temperature)	1.67	--	--	%/°C
	85VAC - 100VAC	1.33	--	--	%/VAC
Safety Standard		Design refer to UL/EN/IEC62368-1			
Safety Class		CLASS I			
MTBF		MIL-HDBK-217F@25°C ≥ 1000,000 h			

Mechanical Specifications

Case Material	Black plastic, flame-retardant and heat-resistant (UL94V-0)	
Dimension	Horizontal package	63.14 x 60.60 x 12.70mm
Weight	Horizontal package	140g (Typ.)
Cooling Method	Using from the Al-Substrate to additional heat radiation of the radiator cooling	

Electromagnetic Compatibility (EMC) (Based on recommended circuit)*

Emissions	CE	CISPR32/EN55032 CLASS A	
		CE102 GJB151B	(See Fig. 3 for recommended circuit)
	RE	CISPR32/EN55032 CLASS A	
	Harmonics	IEC/EN61000-3-2	perf. Criteria A
Immunity	ESD	IEC/EN61000-4-2	Contact ±6KV/Air ±8KV perf. Criteria B
	RS	IEC/EN61000-4-3	10V/m perf. Criteria A
	EFT	IEC/EN61000-4-4	±2KV perf. Criteria B
	Surge	IEC/EN61000-4-5	line to line ±2KV/line to PE ±4KV perf. Criteria B
	CS	IEC/EN61000-4-6	10V.r.m.s perf. Criteria A
	Voltage dip, short interruption and voltage variation	IEC/EN61000-4-11	0%, 70% perf. Criteria B

Note: *Except for CE102 of the CE, other EMC test results are based on recommended circuit 1, 2.

Instructions

1. ENA Remote Control Switch

The module has built-in ENA remote control switch function. This function can control ON/OFF of the output voltage when the input voltage is turned on. Short circuit ENA and HU-, and the output voltage is normal; ENA disconnect to HU- , and the output voltage turn off. The wiring diagram circuit is as follows:

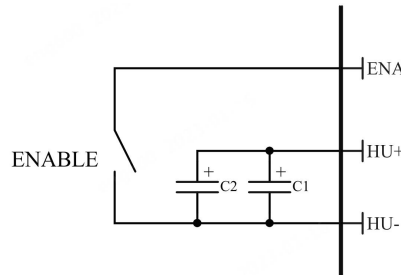

2. Auxiliary Power Supply For External Signals (AUX Terminal)

The module additionally provides 12V auxiliary source output, the reference ground is HU- and provides an auxiliary control power supply for the primary side control circuit. No load voltage 8-15V (internal resistor in series 1 kΩ , maximum pulling current about 10mA).

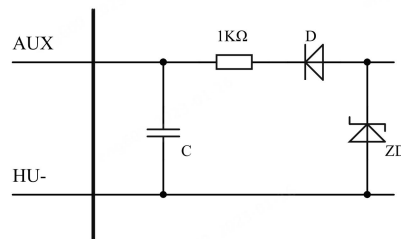

Product Characteristic Curve

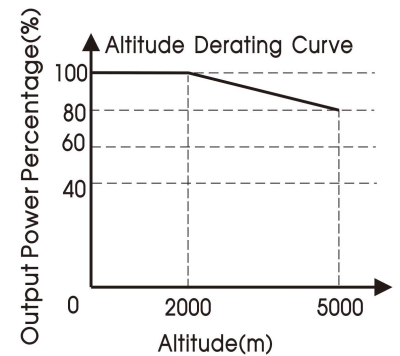
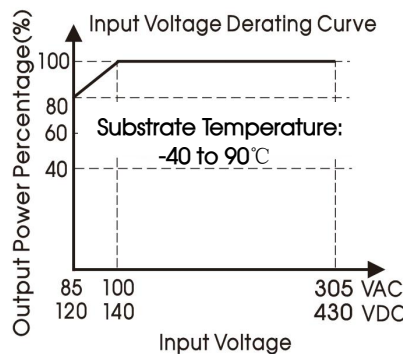
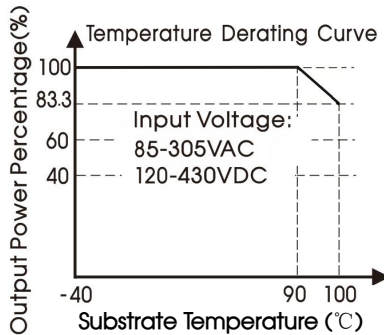

Note:

- ① With an AC input voltage between 85 - 100VAC/120 - 140VDC the output power must be derated as per the temperature derating curves;
- ② This product is suitable for applications using natural air cooling; for applications in closed environment please consult Mornsun FAE.

Product Test Waveform

1. Dynamic Response

Test conditions: $T_c=25^{\circ}\text{C}$, $V_{in}=230\text{VAC}$, $V_{out}=12\text{V}$, 20MHz bandwidth. Products are tested based on recommended circuit and the "parallel cable" method is used for test, output parallel 10uF electrolytic capacitor and 1uF ceramic capacitor.

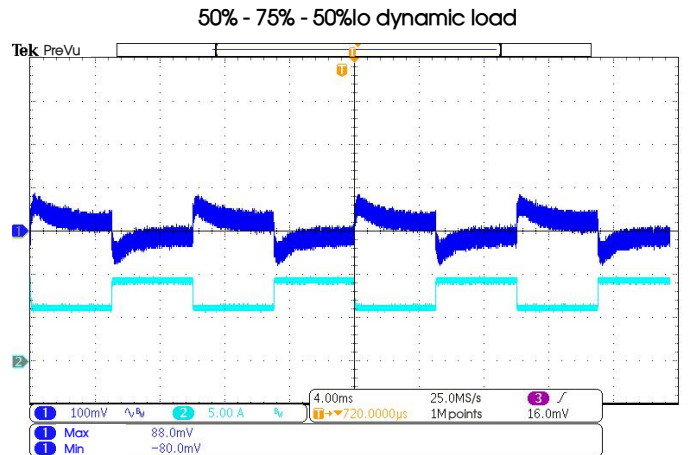
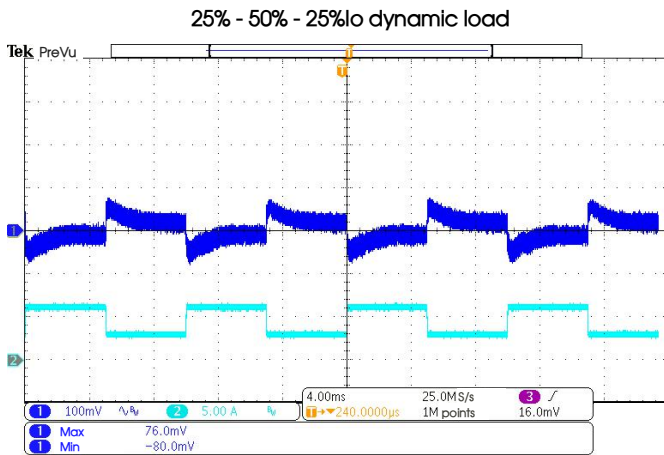

2. Output Ripple And Start-up Waveform

Test conditions: $T_c=25^{\circ}\text{C}$, $V_{in}=230\text{VAC}$, $V_{out}=12\text{V}$, 20MHz bandwidth. Products are tested based on recommended circuit and the "parallel cable" method is used for test, output parallel 10uF electrolytic capacitor and 1uF ceramic capacitor.

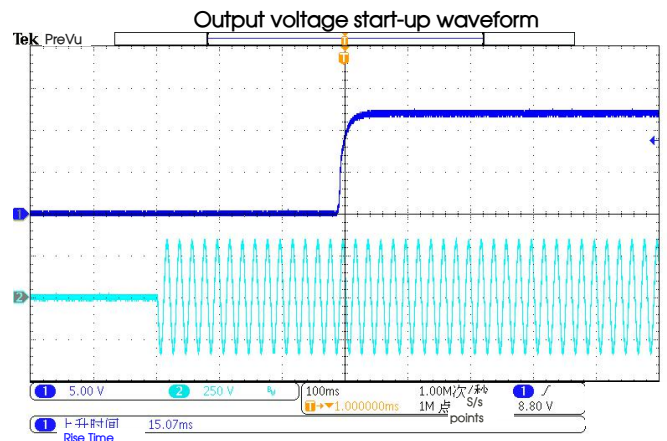
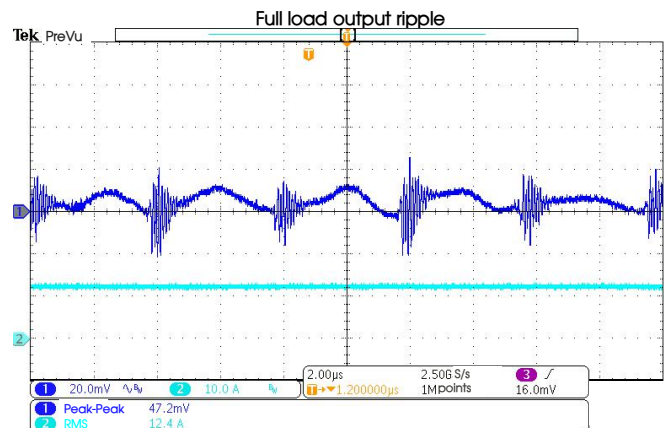

3. Conductive Waveform

(1) Safety specifications: CISPR32/EN55032 CLASS A

Test conditions: $T_c=25^{\circ}\text{C}$, $V_{in}=230\text{VAC}$, $V_{out}=12\text{V}$, products are tested based on recommended circuit.

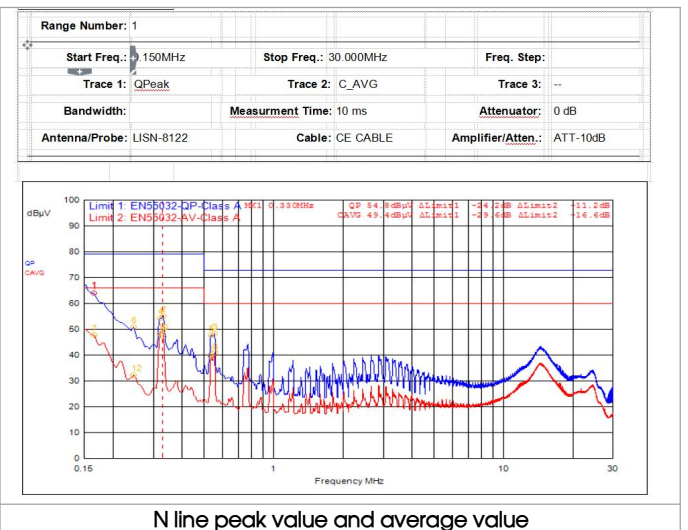
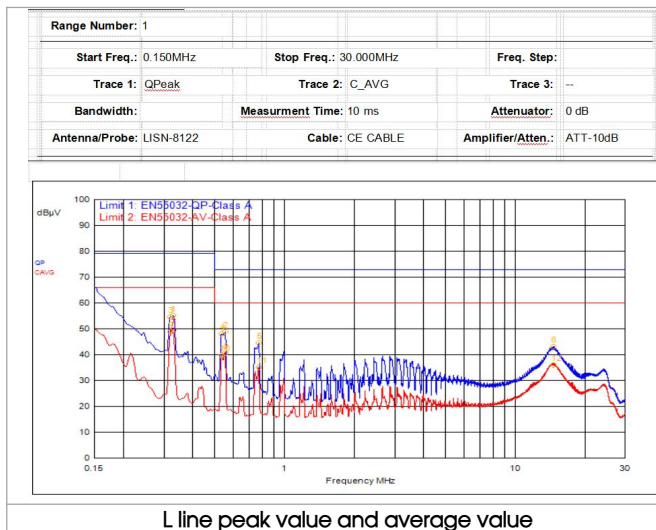

(2) Safety specifications: CE102 GJB151B

Test conditions: $T_c=25^{\circ}\text{C}$, $V_{in}=220\text{VAC}$, $P_{out}=150\text{W}$, products are tested based on recommended circuit 3.

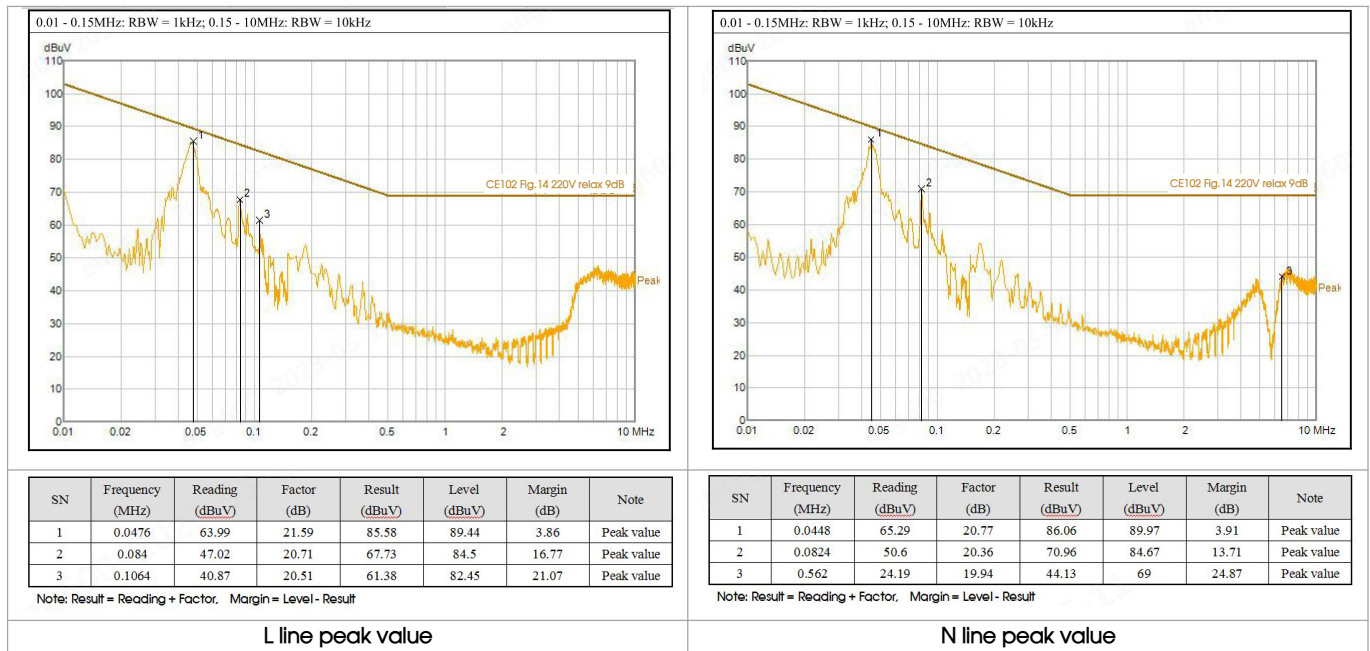

Additional Circuits Design Reference

1. Typical application

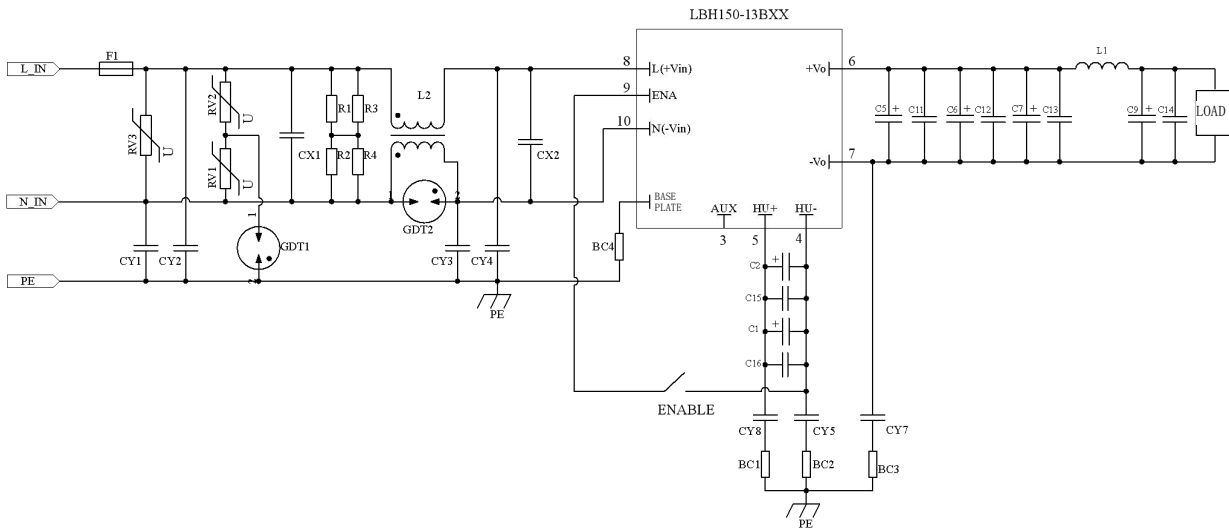

Fig. 1: Recommended circuit 1

Required Component	
Component	Recommended value
F1	3.15A/300VAC show-blow
L2	10mH/145mΩ, Max/3A (recommend MORNSUN P/N: FL2D-30-103)
C1/C2	82uF/450V (C1+C2≤200uF)*
CX1/CX2	105K/310VAC
C5/C6/C7	12V 1000uF/16V (solid-state capacitor)
	24V/28V 470uF/35V
	48V/54V 220uF/63V

C11/C12/C13/C14	12V	106K/1206/25V
	24V/28V	105K/1206/50V
	48V/54V	104K/1206/100V
L1	12V	0415/0.39uH/30A
	24V/28V/48V/54V	0415/0.8uH/15A
C9	12V	1000uF/25V
	24V/28V	470uF/35V
	48V/54V	220uF/63V

Note: *C1+C2 total value exceeds specifications, these is a risk of damage to the product.

EMC Component	
Component	Recommended value
RV1/RV2	14D471K/4500A
RV3	14D561K/4500A
GDT1	3.6KV/3KA
GDT2	300V/1KA
R1/R2/R3/R4	2M Ω /1206
CY1/CY2/CY3/CY4/CY5/CY7/CY8	Y1/102M/400VAC
BC1/BC2/BC3/BC4	47 Ω /100MHz (Magnetic bead)
C15/C16	683K/1210

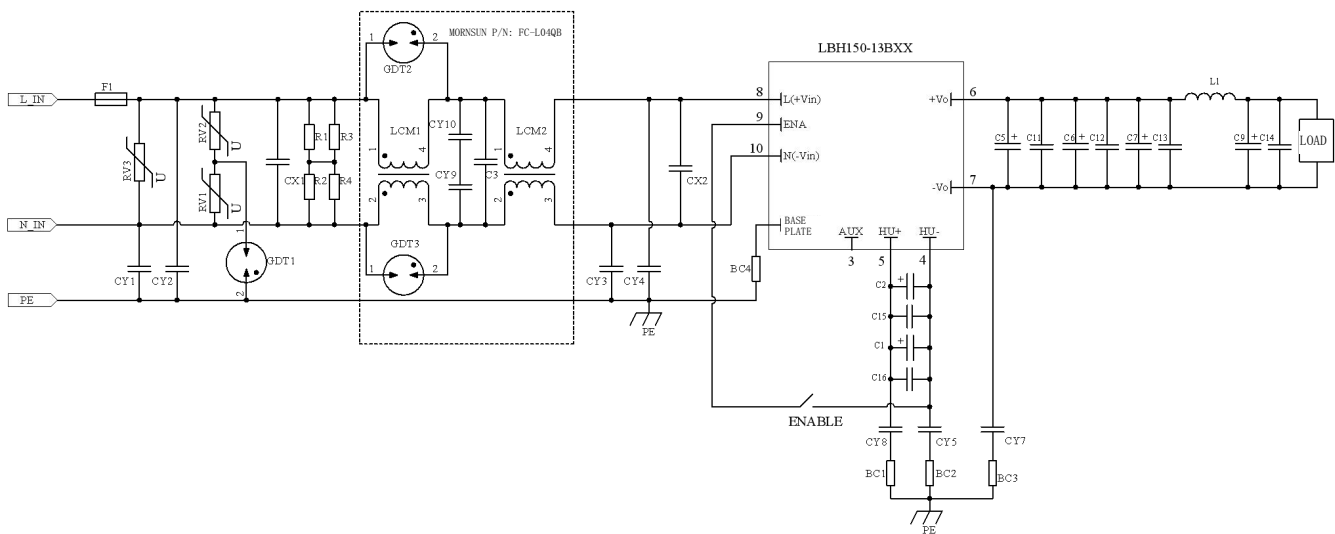

Fig. 2: Recommended circuit 2

Component	Recommended value	
CX1	105K/310VAC	
CX2	225K/310VAC	
MORNSUN P/N: FC-L04QB*	LCM1	5mH
	LCM2	100uH
	GDT2/GDT3	90V/500A/3216
	CY9/CY10	Y1/222M/400VAC
C3	Y2/103M/300VAC	

Note: 1. The external circuit component parameters are the same as those of the above recommended circuit 1;
2. *P/N: FC-L04QB (MORNSUN) is preferred, the effect of the self-built circuit is greatly affected by magnetic material and layout.

2. Conducted emission (CE102) recommended circuit

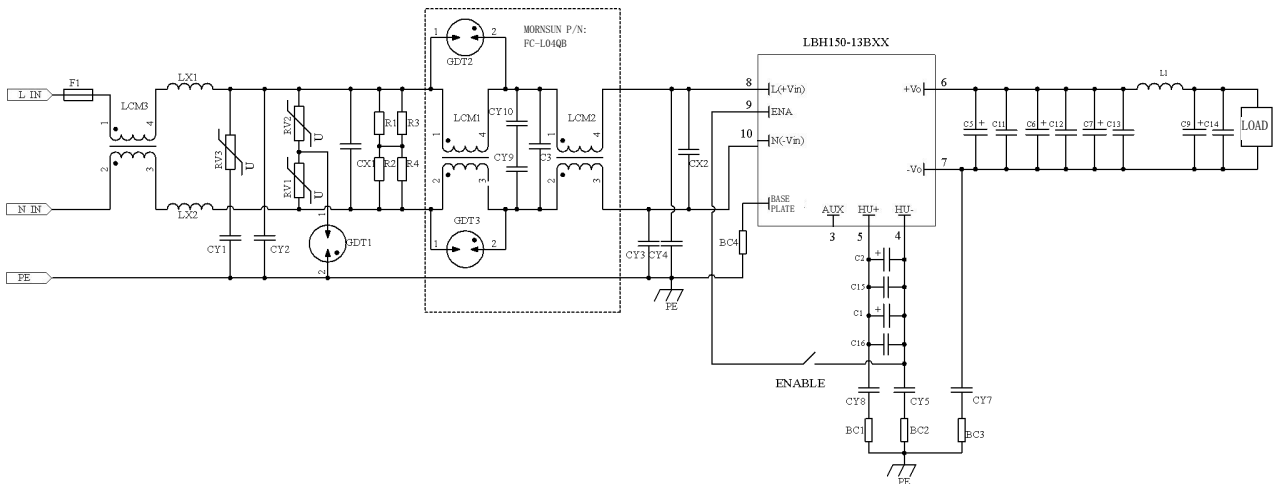

Fig. 3: Recommended circuit 3

Component	Recommended value	
CX1	105K/310VAC	
CX2	225K/310VAC	
LX1/LX2*	2mH/Min: 2A	
LCM3*	5.6mH/Min: 2A	
MORNSUN P/N: FC-L04QB	LCM1	5mH
	LCM2	100uH
	GDT2/GDT3	90V/500A/3216
	CY9/CY10	Y1/222M/400VAC
	C3	Y2/103M/300VAC

Note: 1.The external circuit component parameters are the same as those of the above recommended circuit 1;
2. *LX1/LX2/LCM3 inductor is not available for sale in Mornsun;
3. P/N: FC-L04QB (MORNSUN) is preferred, the effect of the self-built circuit is greatly affected by magnetic material and layout.

3. For additional information please refer to application notes on www.mornsun-power.com

Dimensions and Recommended Layout

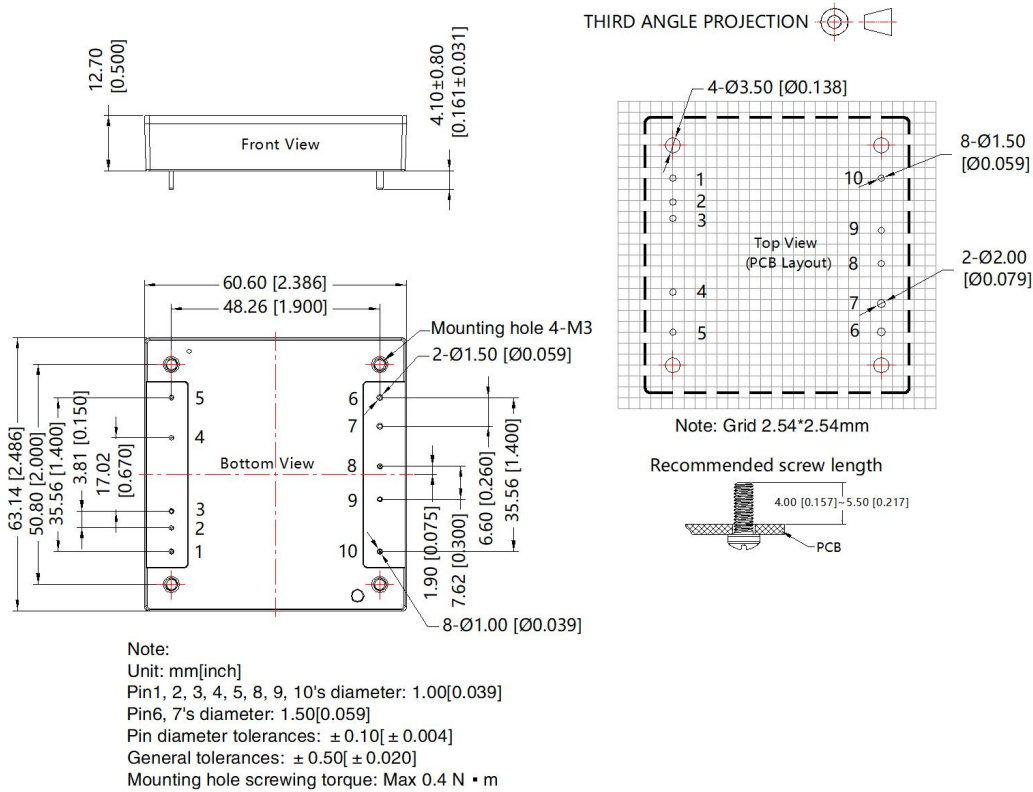

Pin description					
1	NC	Open	6	+Vo	Positive DC output
2	NC	Open	7	-Vo	Negative DC output
3	AUX	Output of auxiliary source, reference HU-	8	L(+Vin)	AC input Line/Positive DC input
4	HU-	Keep the capacitor voltage negative	9	ENA	Switch enable pin
5	HU+	Keep the capacitor voltage positive	10	N(-Vin)	AC input Neutral/Negative DC input

- Note:
- For additional information on Product Packaging please refer to www.mornsun-power.com. Packaging bag number: 58200069;
 - If the product is not operated within the required load range, the product performance cannot be guaranteed to comply with all parameters in the datasheet;
 - Unless otherwise specified, parameters in this datasheet were measured under the conditions of Ta=25°C, humidity<75% with nominal input voltage and rated output load;
 - All index testing methods in this datasheet are based on our company corporate standards;
 - We can provide product customization service, please contact our technicians directly for specific information;
 - Products are related to laws and regulations: see "Features" and "EMC";
 - If product involves multi-brand materials and there are differences in color etc, please refer to the standards of each manufacturer.
 - Our products shall be classified according to ISO14001 and related environmental laws and regulations, and shall be handled by qualified units.

Mornsun Guangzhou Science & Technology Co., Ltd.

Address: No. 5, Kehui St. 1, Kehui Development Center, Science Ave., Guangzhou Science City, Huangpu District, Guangzhou, P. R. China
Tel: 86-20-38601850 Fax: 86-20-38601272 E-mail: info@mornsun.cn www.mornsun-power.com